

TVL 275
ISSUE 0
02/05



**MICROPROCESSOR LIFT
CONTROL MANUAL
(BUCHER HYDRAULIC VVVF)
FOR
POWERED DOORS
APPLICATIONS**

CONTENTS

<u>1.0</u>	<u>INTRODUCTION</u>	<u>PAGE 3</u>
1.1	General	3
1.2	Construction	4
1.3	Overall System Description	4
1.4	Performance Characteristics	5
1.4.1	Electrical	5
1.4.2	Mechanical	6
1.5	Microprocessor System Description	6
<u>2.0</u>	<u>INSTALLATION & COMMISSIONING</u>	<u>PAGE 7</u>
2.1	General	7
2.2	Connector Access	7
2.3	Microprocessor/System Connection	7
2.4	Control Panel Switch-on	7
2.5	Microprocessor Switch-on	8
2.6	Call Entry	8
2.7	Homing	8
2.8	Stuck Push Button	8
2.9	Call Designations	9
2.10	Motherboard I/O Designations	10
2.11	I/O Card Designations	11
<u>3.0</u>	<u>OPERATING PROCEDURES</u>	<u>PAGE 14</u>
3.1	Visual Indicators	14
3.1.1	Power Supply Unit	14
3.1.2	Display/Keypad	14
3.1.3	CPU Card	14
3.1.4	I/O Cards	14
3.1.5	Motherboard	15
3.2	Audible Indicators	15
3.2.1	Keypad	15
3.2.2	Event Log	15
3.2.3	Limited Force Door Closing	15
3.3	Switches	16
3.3.1	CPU and Configuration Switches	16
3.3.2	Reset Push Button	17
3.3.3	DDS & PTT Switch	17
3.3.4	Double Journey Relay (DJR)	18
3.4	Control Functions	18
3.4.1	Normal Control (Simplex Full Collective)	18
3.4.2	Duplex Control	19
3.4.3	Fire Control	20
3.4.4	Service Control (Car Preference)	21
3.4.5	Weight Switch 95% (By-Pass)	21
3.4.6	Weight Switch 110% (Car Overload)	21

3.5	ONIX Evolution MMI (Man / Machine Interface)	22
3.5.1	Overview of MMI control panel	22
3.5.2	Overview of Menu System	23
3.6	Event Logger	26
3.6.1	The Event Messages	27
3.6.2	Event Logger With Date and Time Recording	29
3.6.3	Event Code Description	30
3.7	Counters	40
3.8	Calls	40
3.9	Settings	41
3.9.1	Date and Time	41
3.9.2	Timers	42
3.9.2.1	Timer Settings	43
3.9.3	Return and Recall	44
3.9.4	Door Settings	44
3.9.5	Feature Settings	44
3.9.6	Floor Settings	45
3.10	Change Passwords	46
3.11	Software Version	46
3.12	Configuration	46
<u>4.0</u>	<u>TECHNICAL DESCRIPTION</u>	<u>PAGE 47</u>
4.1	Motherboard	47
4.2	Power Supply	47
4.3	CPU Card	47
4.4	Watchdog-Loop Flag Monitor	48
4.5	Audible Warning	48
4.6	Pushbuttons	48
<u>5.0</u>	<u>OVERHAUL & REPAIR</u>	<u>PAGE 49</u>
5.1	Handling of EPROM's	49
5.2	Fault Finding Procedures	49
<u>6.0</u>	<u>ILLUSTRATIONS</u>	<u>PAGE 51</u>
Fig 1	Motherboard Card Positions/Wiring Schematic	51
Fig 2	EPROM Changing Instructions	52
<u>7.0</u>	<u>ADDENDUM</u>	<u>PAGE 53</u>
7.1	Bucher fault codes	53
7.2	Bucher ELRV-VVVF timing sequence	54

1.0 INTRODUCTION

1.1 GENERAL

The TVC ONIX 'Evolution' Microprocessor Lift Control Module is one of the latest modules supplied by TVC which make up a lift control system. The module is designed using current technology to provide a cost-effective lift control panel whilst maintaining all the safety, reliability and flexibility features associated with Thames Valley products and at the same time giving even more customer facilities.

In addition to the normal features a number of refinements are included as standard; these include, for example, recognition of a stuck button (which is consequently ignored), LED indication of each incoming and outgoing signal, a display of the lift position and direction of travel and on request displays of certain past and present lift events which are displayed in 'English Language'.

Features provided by the system include:

- a) Fireman Control and Indicator
- b) Special Service Control (Car preference)
- c) Homing
- d) Landing Door Re-open Once
- e) Light Ray Failure
- f) Stuck Button Detection
- g) Differential Door Timing
- h) Advance Call Cancel
- i) Door Open Push
- j) Door Close Push
- k) Weight Switch 95%, 110% and Overload Indicator
- l) Car Call Dumping
- m) Event Message Display (in 'English Language' and real time)
- n) Door Opening and Closing Protection
- o) 3 Wire Indicator System
- p) Floor security facility
- q) Journey and Door operation counters

1.2 CONSTRUCTION

The system comprises a motherboard onto which a number of printed circuit cards are mounted (see Fig 1.0). Connections to the motor panel are achieved via two part connectors on the motherboard. Shaft and car wiring are via screw-clamp type terminals also on the motherboard.

The system voltages are derived from a transformer/power supply module mounted on the motor panel and are fed via a wiring loom to the microprocessor motherboard.

1.3 OVERALL SYSTEM DESCRIPTION

The overall TVC Microprocessor Collective Lift Control System comprises a Microprocessor Unit and a Motor Panel Section plus Shaft and Car wiring.

The overall system is built around the 6809 Microprocessor which is used as the control centre for monitoring and addressing all incoming and outgoing signals to the remainders of the system.

The lift motor operation is controlled by the Motor Panel Section which receives signals from the Microprocessor, such as pilot up, pilot down, pilot high speed, pilot open doors and pilot close doors. The Motor Panel Section sends signals back to the Microprocessor Unit regarding which lift function it is carrying out, i.e. moving up, moving down, opening or closing doors, door zone or locks made etc.

The Motor Panel Section also transmits signals to and receives signals from the shaft and car, these being locks and safety circuit signals from the shaft wiring, door operator, car gate and safety circuit signals from the car wiring.

Signals to and from the shaft and car are also transmitted and received by the Microprocessor Unit. These include landing calls, position indicators, position resets and fire switch etc, from the shaft wiring and car calls, position indicators, service switch, etc, from the car wiring.

Duplex operation is possible, as is connection to an 'EMU' remote monitoring system. There is a separate manual detailing connection requirements etc, for these features.

High reliability, field proven industrial standard components are used throughout the system and are readily available from many sources.

The system has signal protection, where all external incoming signals are optically isolated and filtered. Motor Panel signals are normally at 110V AC and all other incoming signals are at 100V DC, with the exception of landing and car push feed which is 24V DC.

The Microprocessor System regularly tests itself throughout its operation and in its program, if an error is detected the system will automatically reset itself.

Specific Fault Events which may occur during lift operation are recognised and recorded by the system.

1.4 PERFORMANCE CHARACTERISTICS

1.4.1 Electrical

System Input voltage: 400V ac + 10% - 10% 50/60 HZ.

Note: other voltages available - consult factory.

Power Supply Module Voltages

	ONIX POWER SUPPLY			
Input Voltage	9V (30VA)	19V (50VA)	75V (75VA)	
Fuse Ident Rating	9V 2A a/s	19V 3A a/s	75V 1A a/s	
Output Voltage	+10V dc	+24V dc	+100V dc	
Fuse Ident Rating	10V 1A	CAF 1A	LAF 1A	24V 2A 100V 500mA

Note 1: Fuses not denoted a/s are quick-blow.

Note 2: The 5V supply is derived from the 10V supply via a voltage regulator fitted on the motherboard.

CPU Card	-	+5Vdc Power
	-	+10Vdc Power
24 Input I/O Card (Calls)	-	+5Vdc Power
	-	+24Vdc Power
	-	Each input signal is activated by ref. to OV
22 Outputs	-	Output Relays
	-	Single contact per relay
	-	Contact Rating 5A at 250Vac
	-	Coil Voltage 24Vdc
28 Input Card (All Other Inputs)	-	+5Vdc Power
	-	+24Vdc Power
	-	Each input signal is sourced from 100Vdc (and must exceed 75Vdc) via Motherboard
28 Output Board	-	+5Vdc Power
	-	+24Vdc Power
Display/Function Board	-	+5Vdc Power
	-	24Vdc Power

- | | | |
|-------------|---|--|
| Motherboard | - | +24Vdc Power |
| | - | +10Vdc Power |
| | - | Two /RS232 serial communications ports |
| | - | Output Relays |
| | - | Single contact per relay |
| | - | Contact Rating 5A at 250Vac |
| | - | Coil Voltage 24Vdc |

Environmental Range

Humidity Operating Range	0 - 90% relative humidity (non-condensing)
Temperature Operating Range	5 - 40 deg. C ambient

1.4.2 Mechanical

Main Motherboard Assembly	Height	223mm
	Width	260mm
	Depth	145mm
	Weight	4.5Kg

1.5 MICROPROCESSOR SYSTEM DESCRIPTION

The Microprocessor System comprises a number of printed circuit cards, all of which are mounted on the motherboard. These are namely:

- a) The Motherboard itself which contains the basic pilot motion control relays and the inputs which go to and come from the Panel. It also contains the DJR journey timer and serial communication ports.
- b) The Central Processor Unit (CPU) board which contains the program, control components SW3, SW4, RESET PUSH and DIL switches are also mounted on the board for configuration purposes.
- c) A 24 way I/O board for call inputs and call acceptance outputs.
- d) A 28 way Input board for all other incoming signals (external and main panel).
- e) A 28 way Output board for driving the Motherboard relays.
- f) A display/function board, which contains an LCD, display for Position, EVENTS and parameter viewing. Six Pushbuttons for obtaining the above information, configuration and parameter adjustment.

2.0 INSTALLATION & COMMISSIONING

2.1 GENERAL

The external wiring for the Microprocessor controlled system is as shown in Fig 1

All car and landing call pushes are at 24Vdc potential - switched to ground.

All other incoming wiring to the Unit are at 100V dc and all outgoing wiring for Indicators are at 24V dc.

2.2 CONNECTOR ACCESS

All external wiring to the ONIX processor unit is made to the Motherboard terminals.

2.3 MICROPROCESSOR / SYSTEM CONNECTION (REF. FIG 1)

Transformer /PSU Connections (mounted on the Motor Panel)

i) Transformer Input

The appropriate voltage tapping should be selected on the PSU transformer to suit the application.

ii) PSU Outputs

Power Supply Unit outputs go via a separate loom to socket Con 3 on the Microprocessor Motherboard.

Note: This is normally factory wired...

2.4 CONTROL PANEL SWITCH-ON

Before switching on for the first time, carry out the following procedure:

- a) Disconnect the power loom from connector Con 3 at the Microprocessor Motherboard.
- b) Pull all the plug-in Cards out approximately 12mm.
- c) Interrupt the supply to the transformer/PSU (this is done because at this stage microprocessor operation is not required).

Switch on the control panel and ensure that no 110 or 230 VAC wiring has been connected to any of the connectors on the right hand side or the bottom of the motherboard.

When the wiring has been fully checked out, switch off and then reverse the procedures a, b and c above.

2.5 MICROPROCESSOR SWITCH-ON

After switching on, the following checks should be made:

- a) i) The two power supply LED indicators (top left) should be illuminated, to show that the +5V and +24V are available at the Motherboard.
- ii) If there is an earth fault on CT1 or CT2 the 100V fuse will blow.

(All fuses on the ONIX Power Supply are 20mm fuses).

- a) The LCD Display Board shows the position of the lift when it was last switched off. If not on a terminal reset with a door zone registered the lift will, after a short delay "Dive" to the bottom floor.
- b) The green LED on the CPU card designated "Loop" should flash continuously.
- c) For a short time the EVENT CODE will display "POWER ON RESET". It maybe over-ridden by a "LOST LAR" which remains displayed. A "LOST LAR" indicated that the lift has a primary safety circuit failure because the LAR relay is de-energised.
- d) On the I/O cards, any of the red LED's illuminated shows that an incoming signal is present (refer to 2.11 for signal notations). The yellow LED's indicate that the associated output relay has been energised (refer to 2.11).

2.6 CALL ENTRY (ELECTRICALLY AND VIA KEYPAD)

Car and Landing calls can be entered using the ONIX MMI keypad. See 3.8 for further details.

Alternatively, Car calls and landing calls can be entered by grounding any of the appropriate terminals. CC1 to CC2 for Car Calls and LU1 to LD2 for Landing Calls. If done correctly the corresponding output relay will energise and LED will light indicating that the call has been accepted.

2.7 HOMING

The lift will "Home" to the main floor (or a floor specified by the customer) when HOMEN is switched to on. See 3.3.1.

2.8 STUCK PUSH BUTTON

The MPU automatically reads the input signal when a call button is pressed, memorises it and compares it with the previous input signals.

If both signals are the same the command is ignored by the system until the stuck button is released and re-operated.

2.9 CALL DESIGNATIONS

FULL COLLECTIVE

FLOOR	CAR CALLS	UP-LANDING CALLS	DN-LANDING CALLS
7	CC7		LD7
6	CC6	LU6	LD6
5	CC5	LU5	LD5
4	CC4	LU4	LD4
3	CC3	LU3	LD3
2	CC2	LU2	LD2
1	CC1	LU1	

DOWN COLLECTIVE/NON SELECTIVE COLLECTIVE/APB

FLOOR	CAR CALLS	LANDING CALL
7	CC7	LD7
6	CC6	LD6
5	CC5	LD5
4	CC4	LD4
3	CC3	LD3
2	CC2	LD2
1	CC1	LU1

Note: APB operation

Ensure DIL switch 1 position 5 is "ON" refer to section 3.3.1

2.10 MOTHERBOARD I/O DESIGNATIONS

Motherboard Inputs:-

15 Opto-isolated inputs rectified and smoothed.
Direct input from control circuit (110/230V ac or 110V dc)

Main panel monitoring inputs:

1	LAR	Normal control relay
2	MUP	Door zone switch
3	MDN	LSC output monitor
4	SPX	Selector stepping switch
5	TTR	Lift on test control
6	OC	Door open relay
7	CC	Door close relay
8	DOL	Door open limit
9	DCL	Door close limit
10	CG	Car gate contact
11	GL	Landing gate closed contact
12	MC	Main motion contactor/Delta
13	LU	Levelling up switch
14	LD	Levelling down switch
15	NO ERR/ERR	Motor overload/double journey monitor.

Motherboard Outputs to main panel:-

Main panel pilot relays:

1	LDL	Low speed time limit
2	PUR	UP direction pilot
3	PDR	DOWN direction pilot
4	HSR	High speed UP pilot
5	LSR	Valve shut off
6	LSC	Advance door open/re-level enable
7	SP01	High speed down pilot
8	DOPR	Door open pilot
9	DCLR	Door close pilot
10	NUG	Door nudging pilot

2.11 I/O CARD DESIGNATIONS

INPUT CARD 1 - 28 OPTO-ISOLATED INPUTS

INPUT 1 - 15 RECTIFIED AND SMOOTHED DIRECT INPUT FROM CONTROL CIRCUIT (110V AC/DC)

IP1	LAR	Lift on Normal
IP2	MUP	Door Zone Signal
IP3	MDN	LSC Output Monitor
IP4	SPX	Selector Stepping Switch
IP5	TTR	Lift on Test Control
IP6	OC	Door Opening
IP7	CC	Door Closing
IP8	DOL	Door Open Limit
IP9	DCL	Door Close Limit
IP10	CG	Car Gate Contact
IP11	GL	Landing Gate Closed Contact
IP12	MC	Main Motion Contactor/Delta
IP13	LU	Levelling Up Switch
IP14	LD	Levelling Down Switch
IP15	NO ERR/ERR	Motor overload/double journey monitor.

INPUTS 16 - 28 (100VDC SMOOTHED)

IP16	FSR	Fire Control Switch
IP17	SSR	Car Preference Switch
IP18	WS110	Weight Switch 110% (Overload)
IP19	WS95	Weight Switch 95% (By-Pass)
IP20	EMR	Top Final Limit Operated
IP21	DCP	Door Close Push
IP22	BB	Light Beam Broken
IP23	SE	Safety Edge
IP24	DOP	Door Open Push
IP25	BFR	Bottom Floor Reset
IP26	TFR	Top Floor Reset
IP27	SI1	UP Direction Signal
IP28	SI2	Down Direction Signal

I/O Card Designations (continued)

INPUT/OUTPUT CARD 2 - 24 OPTO-ISOLATED INPUTS
- 24 RELAY OUTPUTS

Each Input/Output is 24V potential pulled to ground to activate, then held to ground by the on board relay, apart from CAF and LAF which are sourced from 24Vdc.

1	LAF	Landing Call Indicator Feed
2	CAF	Car Call Indicator Feed
3	LU7	Emergency Recall/Fire Alarm Recall
4	LU6	Landing Up Call Floor 6
5	LU5	Landing Up Call Floor 5
6	LU4	Landing Up Call Floor 4
7	LU3	Landing Up Call Floor 3
8	LU2	Landing Up Call Floor 2
9	LU1	Landing Up Call Floor 1
10	LD8	SIU Fault
11	LD7	Landing Down Call Floor 7
12	LD6	Landing Down Call Floor 6
13	LD5	Landing Down Call Floor 5
14	LD4	Landing Down Call Floor 4
15	LD3	Landing Down Call Floor 3
16	LD2	Landing Down Call Floor 2
17	CC8	Thermistor Overheat
18	CC7	Car Call Floor 7
19	CC6	Car Call Floor 6
20	CC5	Car Call Floor 5
21	CC4	Car Call Floor 4
22	CC3	Car Call Floor 3
23	CC2	Car Call Floor 2
24	CC1	Car Call Floor 1

Note: Shown for full collective - see page 10 for alternative Call Designations.

I/O Card Designations (continued)

OUTPUT CARD - 28 SOLID STATE OUTPUTS, 24V POTENTIAL THAT ARE PULLED TO GROUND TO OPERATE RELAYS MOUNTED ON MOTHERBOARD.

CONTROL CIRCUIT OUTPUTS

OP1 LDL Movement Enable
OP2 PUR Up Direction Pilot
OP3 PDR Down Direction Pilot
OP4 HSR High Speed UP Pilot
OP5 LSR Valve Shut Off
OP6 LSC Advance Door Open/Re-Level Enable
OP7 SPO1 High Speed Down Pilot
OP8 DOPR Door Open Pilot
OP9 DCLR Door Close Pilot
OP10 NUG Door Nudging Pilot

EXTERNAL OUTPUTS

OP11 CGU Lift Going Up - Speech
OP12 CGD Lift Going Down - Speech
OP13 LSI Lift in/out of Service Indicator
OP14 BZR Position Trigger - Speech
OP15 FCI Fire Control Indicator
OP16 OLI Car Overloaded Indicator
OP17 SO1 Lift on Maintenance - Indicator
OP18 SO2 Doors Closing - Speech
OP19 IU Direction Indicator Up
OP20 ID Direction Indicator Down
OP21 PI8 Lift Returning to Lower Level – Speech/Indicator
OP22 PI7 Lift on Car Preference - Indicator
OP23 PI6 Automatic Alarm – Unplanned Stoppage Out of Door Zone with Doors Open
OP24 PI5 Position Indicator Floor 5
OP25 PI4 Position Indicator Floor 4
OP26 PI3 Position Indicator Floor 3
OP27 PI2 Position Indicator Floor 2
OP28 PI1 Position Indicator Floor 1

3.0 OPERATING PROCEDURES

3.1 VISUAL INDICATORS

There are a number of visual indicators used on the Onix processor module to give status of all inputs and outputs and indication of key functions of the system to aid trouble shooting. A brief description of the indicators on the system are given below.

3.1.1 Power Supply Unit

Each voltage developed by the PSU has a red LED associated with it to indicate that power is available to the system. They also show that the relevant fuse is intact. The LED's are: +10Vdc, +24Vdc, +100Vdc

3.1.2 Display/Key pad

LCD display / navigation keys. There are a number of functions available which are detailed in 3.5

3.1.3 CPU Card

- a) Red LED's (2) - These show the direction of travel of the lift, the top one being "UP" and the bottom one being "DOWN".
- b) Green LED (Flashing) - This is the "LOOP" indicator and it indicates that the microprocessor is operating correctly when flashing.

3.1.4 I/O Cards

- a) Red LED's - There is a number on each Input Card and an illuminated LED indicates that an incoming signal is present.
- b) Yellow LED's - There are 28 on the Output Card and an illuminated LED indicates that an Output Relay is energised.

3.1.5 **Motherboard**

- a) Red LED's - There are two red LED's located at the top left hand side (TXA and TXB). These LED's signify that serial communication (Duplexing etc) is active at the relevant port (CON1 and CON2).
A third red LED will be found bottom left, when lit signifies the DJR relay has tripped.
- b) Green LED's - There are two green LED's located in the left hand corner of the motherboard (+5V and +24V). These LED's signify that the 5V DC and the 24VDC supplies are present on the motherboard.

3.2 **AUDIBLE INDICATORS**

3.2.1 **Key pad**

An audible 'bleep' will be heard on operation of the keypad buttons.

3.2.2 **Event Log**

A 'bleep' warning is initiated when an EVENT CODE is registered.

3.2.3 **Limited Force Door Closing (Nudging) (Event Code 15) (optional)**

Car mounted buzzer, which sounds discontinuously if any of the following conditions occur.

- a) Four door reversals have occurred.
- b) Doors fail to close in 25 seconds due to being held open by the safety edge or, door open push.

3.3 SWITCHES

There are a number of switches located on the front of ONIX CPU board for configuration and feature setting; details of the switches are given below.

3.3.1 CPU and Configuration Switches

In order to configure the processor 2 off 8 way DIL switches are fitted (SW1 and SW2) these are found on the front edge of the CPU board.

SW1 (8 way, Position 1 at the top)

Top Floor Position Reset

Positions 1 to 5 configure the total number of floors.

Position 1 (FL1) Binary 1 floor
Position 2 (FL2) Binary 2 floors
Position 3 (FL4) Binary 4 floors
Position 4 (FL8) Binary 8 floors

LEV	FL1	FL2	FL4	FL8
8	OFF	OFF	OFF	ON
7	ON	ON	ON	OFF
6	OFF	ON	ON	OFF
5	ON	OFF	ON	OFF
4	OFF	OFF	ON	OFF
3	ON	ON	OFF	OFF
2	OFF	ON	OFF	OFF

Position 5 selects the call collection options:

(APB) ON = APB
OFF = Full collective/down collective

Position 6 not used

Position 7 not used

Position 8 not used

SW2 (8 way, Position 1 at the top)

Position 1 invokes the homing feature:

(HOMEN)	ON	=	Homing enabled
	OFF	=	Homing disabled

Position 2 invokes the lift self test feature:

(LISEN)	ON	=	Lift self test enabled
	OFF	=	Lift self test disabled

Position 3 invokes the anti-nuisance feature:

(ANUEN)	ON	=	Anti-nuisance enabled
	OFF	=	Anti-nuisance disabled

Position 4 invokes the door nudging feature:

(NUGEN)	ON	=	Door nudging enabled
	OFF	=	Door nudging disabled

Ensure the door operator supports door nudging before enabling this feature, as the 'Safe Edge' will be overridden during the nudging process.

Position 5 sets the Lift status signal:

(LISI)	ON	=	LISI (Lift In Service)
	OFF	=	LOSI (Lift Out of Service)

Position 6 Not Used

Position 7 will stop lift motion (for test purposes):

(MOTION)	ON	=	Lift motion enabled
	OFF	=	Lift motion disabled

Position 8 will assign hall call control to the master lift:

(Master)	ON	=	Master lift (Duplex only)
	OFF	=	Slave lift (Duplex only)

Ensure that one lift is set to Master and one lift is set to Slave on Duplex applications, else incorrect hall call handling will be experienced.

3.3.2 Reset Push Button

This momentary action push resets the processor.

3.3.3 Door Disable Switch and Prepare to Test Switch

To assist in maintenance functions two toggle switches are fitted (SW3 & SW4).

SW3	(DDS)	ON	=	Door operation disabled by processor
		OFF	=	Door operation as normal dependent on mode (test, service, fire etc.)

SW4	(PTT)	ON	=	Responds to car calls only, doors park closed in absence of car calls
		OFF	=	Calls accepted as normal dependent on mode (service, fire, etc.)

3.3.4 Double Journey Relay (DJR)

The DJR timer has two ranges:

S	20 - 60 seconds
L	40 - 120 seconds

The range is selected by jumper link (LK2). Fine adjustment is made by potentiometer P1 see Fig 1.0. DJR operation will cause the following sequence of events:

The DJR timer will start timing when inputs MC and LAR are present.

Should the time limit be exceeded, the device will trip and light the 'DJR' LED, The DJR will stay tripped until manually reset even after power down.

The contact of the DJR relay is brought out to terminals for use in the main panel circuitry to remove power from the motion contactors MC1 & MC2. This contact, is placed in series with MOL(n/c) (if fitted) which if tripped will remove the ERR input into the motherboard, thus initiating an emergency hydraulic recall sequence. This mode requires jumper LK1 to be removed.

Note: The DJR Timer should be set for the appropriate site full travel time.

3.4 CONTROL FUNCTIONS

The control functions of the ONIX are similar to the other microprocessor modules manufactured by TVC, the general operation of the main functions are detailed below.

3.4.1 Normal Control (Simplex Full Collective)

Momentary operation of a car or landing push will register that call and its related call acceptance indicator will be illuminated.

Car Calls

Car calls will be intercepted in the order in which the destinations are reached, regardless of the sequence in which they were registered or the current direction of the lift. Car calls are cancelled on intercept at the appropriate landing.

Landing Calls

Landing calls are cancelled on intercept at the appropriate landing if the car is available to accept that particular call. When travelling up the car will stop at a landing for which a car call or an up landing call has been registered, but will not stop at a landing at which only a down landing call has been registered unless the down call is the highest outstanding call.

Similarly, when travelling down, the car will not stop at a landing at which only an up call is registered unless this is the lowest call outstanding. If the car stops at a landing at which both up and down calls are registered, only the call for the direction in which the car is committed will be accepted (and cancelled). Should a car without registered car calls arrive at a landing at which both up and down calls are registered only the landing call for the last direction of travel will be accepted and the previous direction will continue. If no car call is inserted the doors will close after a pre-set interval and if there is then no landing call registered beyond this floor in the last direction of travel, the doors will re-open and cancel the landing call.

If the car fails to start in response to calls within 100 seconds all calls will be cancelled.

The doors are normally arranged to park closed. When fully open, momentary operation of any car call push will cause the doors to close immediately; otherwise the doors will close automatically after a pre-set time interval. The safety-edge contact and/or the light-ray contact connect directly in the microprocessor unit. Opening of the doors cannot be prevented by continuous operation of car-push or door-close push.

3.4.2 Duplex Control (Not required)

The Duplex system consists of two per car lift control panels communicating with each other via a special interconnecting cable. The landing calls are then shared between the two lifts.

The landing calls are entered into both control panels simultaneously by the landing call terminals being interconnected. The assigned 'Master' controller then allocates the call to the most suitable lift taking into account, status, direction, and loading.

If there is communication failure or the serial communication cable is not connected, both lifts will chase any landing calls that are entered.

Ensure that the serial communication cable is connected to both Onix motherboards (CON1) and that the LED (TX1) is flickering. Also ensure that the DIL switch SW2 position 8 is switched 'ON' on one lift only.

CAUTION: The reader should be aware that the Landing call terminals LAF1, L2D to L8D and L1U to L7U of the lift switched off, will still be live (24VDC) because they are sourced from the operational lift

3.4.3 **Fire Control**

Operation of a single pole Fire Control Switch installed on the main landing will immediately initiate Phase 1 Fire Control Return.

Phase 1 Fire Control, the lift will return to the main floor as quickly as possible. The following sequence of operations will occur.

- 1) All calls will be cancelled except the main floor car call.
- 2) If the lift is travelling away from the main floor, the car will slow and stop at the next available landing, the doors will remain closed and following a short delay the lift will start to return to the main floor.
- 3) If the lift is travelling towards the main floor, the lift will continue to the main floor without interruption.
- 4) If the lift is at a landing with its doors open, the doors will close immediately and the lift will proceed to the main floor.
- 5) Throughout the Fire Service Control sequence the "Fire Control" indicator will be illuminated, landing calls will remain inoperative and the Light Ray (or the heat sensitive door devices) will be disabled.
- 6) Once at the main floor the fire fighting lift will park with its doors open and Phase 2 Fire Service operation will begin.

Note: A non-fire fighting lift will close its doors after a short delay to allow for the discharge of passengers and will not respond to any calls.

Phase 2 Fire Service, the following operations will exist on the fire fighting lift:

- a) The doors will only open via constant pressure on the door open push, once they are fully closed. If the push is released before the doors have fully opened they will automatically close. Once the doors are fully open they will remain open until constant pressure of a call push causes them to close. If the call push is released before doors are fully closed, the doors will re-open, all calls be cancelled and the lift will park with its doors open until a car push is re-operated.
- b) The safety edge will be disabled.
- c) Once the lift is moving, extra car calls can be inserted, but the lift will slow at the first call reached in its direction of travel and will cancel all calls upon stopping. The doors will remain closed until signalled to open by constant pressure operation of the door open push.
- d) The lift will only return to normal operation if the fire control switch is in its 'Off' position, the lift is at the main floor and the doors are fully open.
- e) Switching the fire control switch 'Off' for a minimum of five seconds and then to 'On' again, at any time, will always cause the lift to return to the fire floor.

3.4.4 Service Control (Car Preference)

Service or car-preference control is established by operation of a switch in the car. All outstanding calls are cancelled and landing calls cannot be registered.

On SERVICE CONTROL the system is non-collective and all outstanding car calls will be cancelled whenever the doors fully open. If more than one car call push is operated simultaneously then the car will travel to the nearest call and all calls will be cancelled when the doors open.

3.4.5 Weight Switch 95% (By-Pass)

If the car is fitted with a load sensing switch and this switch is closed when the doors are closing, then the by-pass feature operates so that the car cannot stop for intermediate landing calls and will only stop at the first car call encountered. Acceleration or retardation cannot cause inadvertent operation of the by-pass feature.

3.4.6 Weight Switch 110% (Car Overload)

If the car is fitted with a load sensing switch and this switch is closed while the doors are open, the doors will remain open and the OLI (lift overload) output will be turned on until the WS110 is removed.

3.5 ONIX EVOLUTION MMI (Man / Machine Interface)

The ONIX Evolution MMI is an easy to use tool that enables the engineer to view and adjust details stored in the microprocessor. The MMI is used for viewing the lift status, Event Log and adjusting parameters.

3.5.1 Overview of MMI control panel

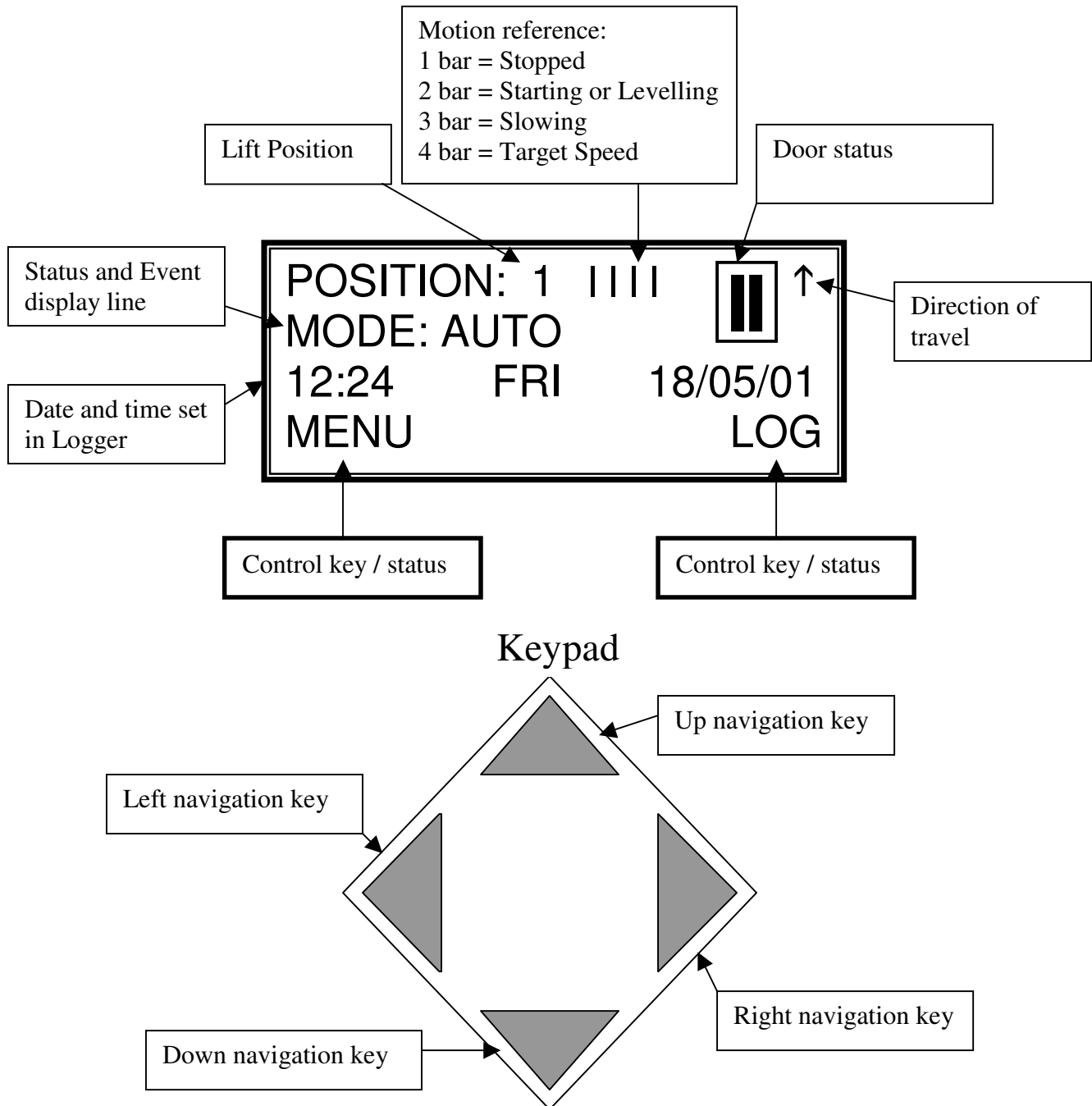

For details of menu options, levels of menu and screens available, please see the following pages

3.5.2 Overview of Menu System

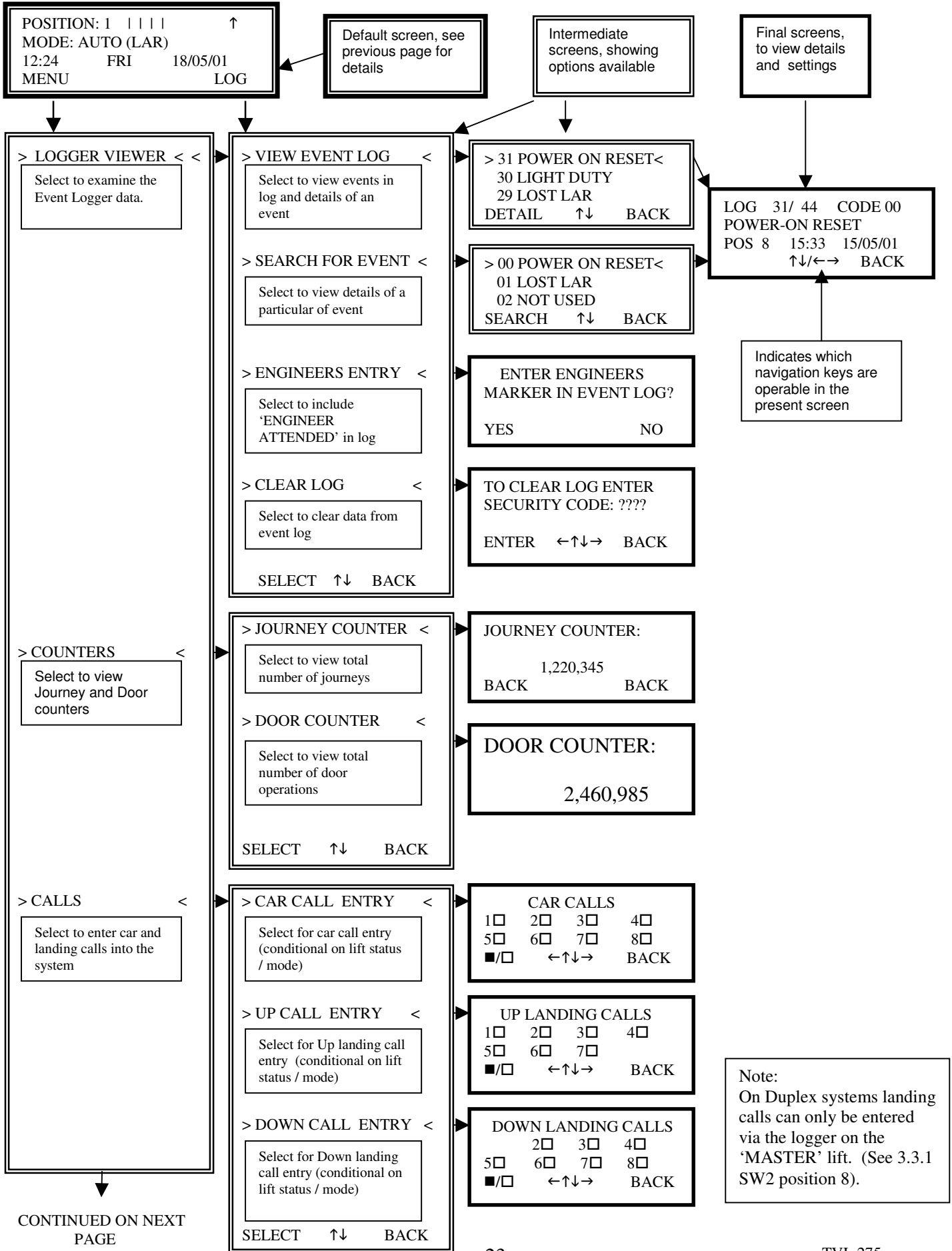

Note:
On Duplex systems landing calls can only be entered via the logger on the 'MASTER' lift. (See 3.3.1 SW2 position 8).

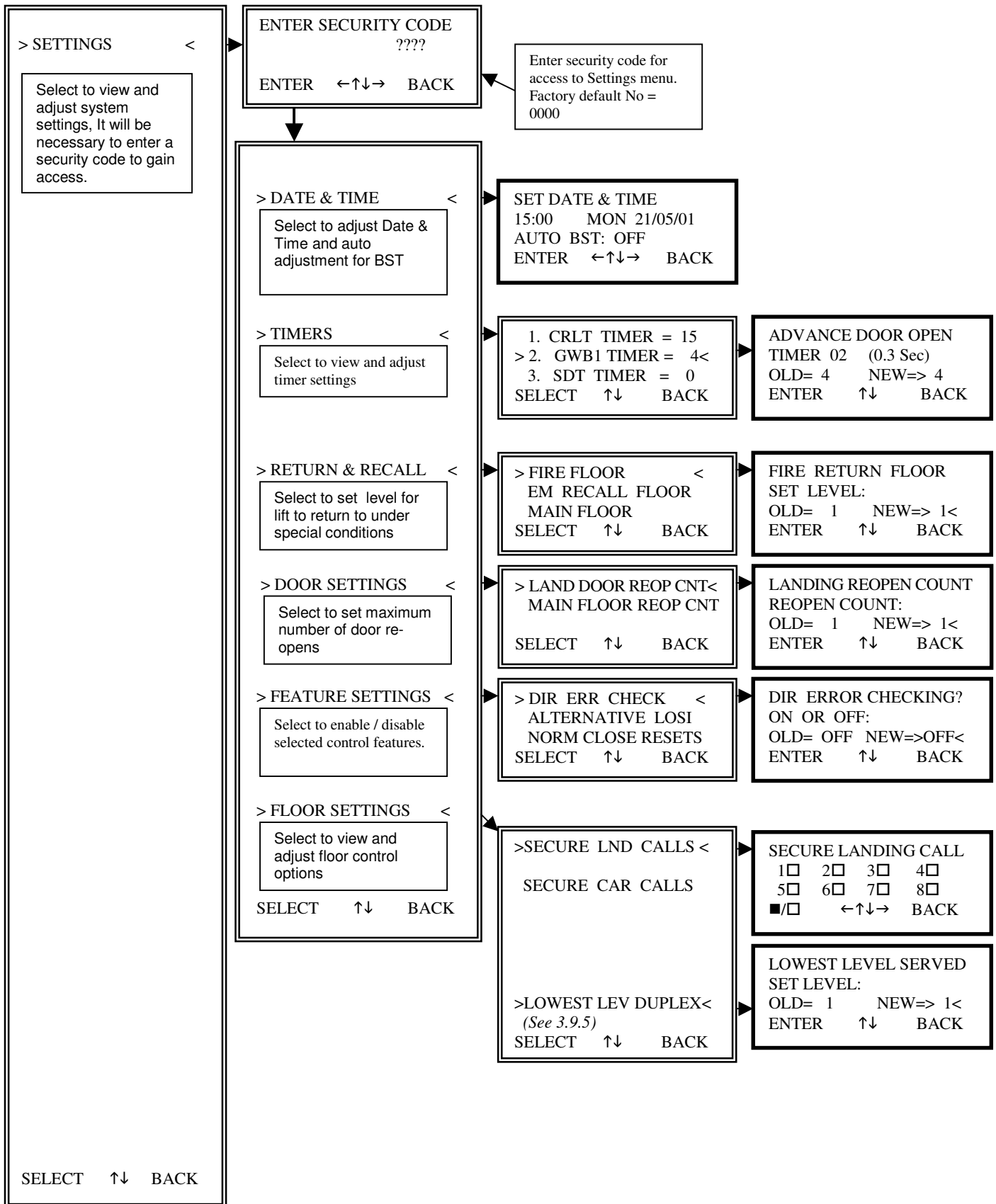

CONTINUED ON NEXT PAGE

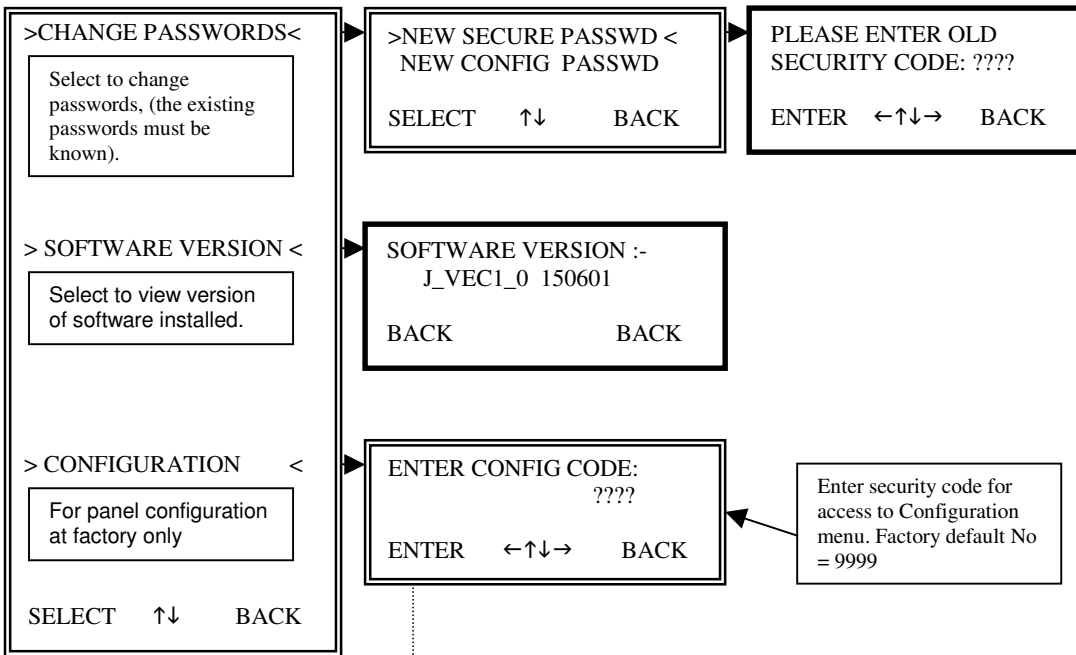

This section is for factory configuration only; any adjustments made should be done with extreme caution.

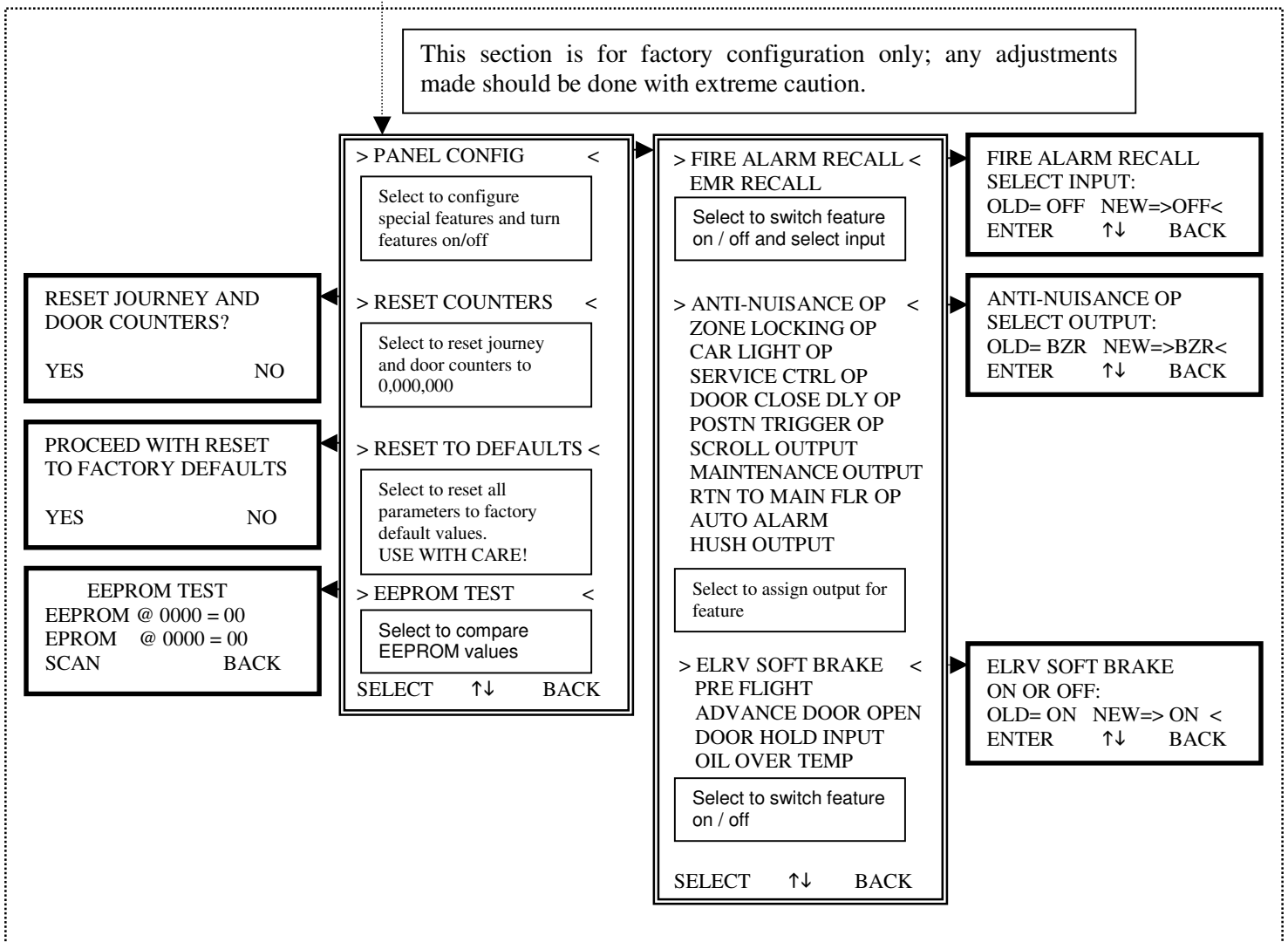

3.6 **EVENT LOGGER**

The Event Logger is a comprehensive engineers tool, which gives a full history of the events that have led up to a breakdown, or simply a history of events that have occurred in the preceding days, weeks and months that may be of interest to the engineer or client. The Event Log detects and records known faults in the system and records Events that are not faults but a change in condition from normal operation.

All Events are recorded in real time together with a calendar, which has the facility of auto adjusting for British Summer Time.

The Events can be examined in chronological order or by specific event if it is required to examine the history of a fault or condition.

The Event Log may be inspected via the LCD control menu, details of which are given later.

The Event Log sub-menu provides for the following four options:

- **[VIEW EVENT LOG]**

To view events in chronological order, the lift position at the time of event and times of events.

- **[SEARCH FOR EVENT]**

To view details of a specific event, the event types are listed in numeric order as listed in the manual, see 3.6.1.

- **[ENGINEERS ENTRY]**

Allows the Engineer to make an "electronic note" of their attendance by entering an marker in the event log.

- **[CLEAR LOG]**

Allows the Engineer to clear the log if required

3.6.1 The Event Messages

As Displayed...	Verbose Description...
(0) POWER-ON RESET	CPU has reset after power-up or "reset" button pushed (see Note 1)
(1) LOST LAR	Lift Available Relay de-energised
(2) NOT USED	
(3) NOT IN DOOR ZONE	Lift stopped outside door zone
(4) D/OPEN PR. T/OUT	Door opening protection fault
(5) GL LOST : STOPPED	Gate lock fault whilst the lift was idle
(6) GL LOST : HI-SPEED	Gate lock tipped whilst the lift was on high speed
(7) GL LOST : LO-SPEED	Gate lock tipped whilst the lift was on low speed
(8) PRE-LOCK FAIL	Gate pre-lock failure
(9) D/CLOSE PR T/OUT	Door closing protection fault
(10) 110% OVERLOAD	Weight switch indicates 110% of full load
(11) ENGN'R ATTENDED	Engineer made note of a previous visit
(12) CALL TF'D/CNCL'D	Call transferred or cancelled
(13) POSITION RESET	The MPU lift position has been reset at a terminal floor
(14) MULT START FAILS	Multiple start failures
(15) DOOR NUDGING	Limited force door closing in operation
(16) RAM FAILURE	CPU Non-Volatile Random Access Memory Failure
(17) STACK ERROR	CPU NVRAM or program failure
(18) SELF-TEST ERROR	Lift-in service self-test error
(19) EPROM FAILURE	CPU program failure
(20) SE OVERTIME	Safety edge is holding the doors open for too long
(21) START FAILURE	Lift has failed to start
(22) EVENT LOG RESET	Event Logger has been reset
(23) – (24) NOT USED	
(25) SIU FAULT	Please see Bucher fault codes at the rear of this manual. Please refer to Bucher manual for latest revision fault codes.
(26) LOST CAR PUSH FD	The feed to the car push has been lost
(27) LOST LDG PUSH FD	The feed to the landing push has been lost
(28) – (30) NOT USED	
(31) GT LOCKS BRIDGED	Gate lock signal present after doors have opened
(32) NOT USED	
(33) LTLR TIMEOUT	Lift has taken excessive time to obtain floor level
(34) LEVELLER ERROR	Levelling proximity/relay contact operated incorrectly
(35) DRIVE ERROR	A drive monitor device has led to motor power removal
(36) STUCK CAR CALL	A car push is stuck or is being held in
(37) STUCK DOWN CALL	A landing down push is stuck or is being held in
(38) STUCK UP CALL	A landing up push is stuck or is being held in
(39) – (41) NOT USED	
(42) *TEST CONTROL*	The lift is currently under Engineer's test control
(43) MULT LEVEL ERRORS	Recorded when event 34 has occurred consecutively three times at the same floor
(44) MULT HEAD ERRORS	Recorded when event 34 has occurred three times

(45) RELEVELLING ERROR	on consecutive journeys Recorded when the lift has failed to reach floor level after releveling
(46) – (49) NOT USED	
(50) LIGHT DUTY	System bias to DOWN calls
(51) – (56) NOT USED	
(57) RTC CLOCK CHANGE	Adjustments to RTC are recorded with new time/date
(58) RTC REGS UPDATE	Corruption of the real time clock data register has been detected
(59), (60) NOT USED	
(61) EMERGENCY RECALL	Recorded when the Emergency Recall switch has been operated
(62) LEVELLER/DIR ERR	Leveller or direction error
(63) NOT USED	
(64) THERMISTER TRIP	Recorded when the Motor Room Temperature monitoring device is exceeded
(65) RTC CLOCK RESET	Out of range time/date value recorded
(66) OIL OVER TEMPERATURE	Recorded when the oil temperature monitoring device is exceeded
(67) NOT USED	
(68) FIRE ALARM RECALL	Lift returns to fire floor - no calls can be entered
(69) LANDING INHIBIT	Set if Landing Calls Disabled due to DDS or PTT
(70) *FIRE SERVICE*	Lift on Fire Service
(71) *SPECIAL SERVICE*	Lift on Special Service
(72) DESPATCH FAILURE	'Bus-stop' routine invoked due to loss of LPF or CPF and homing is enabled.
(73) TOP FINAL LIMIT	Top final limit has been operated
(74) LSC MONITOR ERR	LSC output error
(75) – (81) NOT USED	
(82) PWR ON MEM TEST	Memory error detected on power up
(83) RUN MEM TEST	Memory error detected while running
(84) – (89) NOT USED	
(90) COUNTERS RESET	Journey and door counters have been reset to 0,000,000
(91) LCD OVERFLOW ERROR	LCD screen construction error
(92) LCD INIT FAILURE	LCD module initialisation failure
(93) SETTINGS MENU ENTRY	User has entered the Settings Menu from the secure password entry screen
(94) CONFIG MENU ENTERED	User has entered the Configuration Menu from the config password entry screen
(95) SETTINGS PWD ALTERED	User has changed the settings security password
(96) CONFIG PWD ALTERED	User has changed the config security password
(97) FACTORY DEFAULTS	All parameters have been reset to factory defaults including the event logs, timers, passwords and feature settings
(98) SHADOW SET	Shadow RAM majority verdict
(99) EEPROM BUSY	Miscellaneous serial EEPROM error

Note (1) - The ONIX does not discriminate between a system reset following restoration of the power supply, or a system reset caused by manual operation of the "reset" pushbutton on the CPU card - either will result in "POWER-ON RESET" entries being made in the event log.

Whenever one of these events occurs, the system displays the appropriate event message for four seconds and bleeps a warning. The event and the corresponding position of the lift are appended to the event log, which is held in non-volatile memory, so that the contents are maintained even if power is lost.

Note: Event "GT LOCKS BRIDGED" (Gate Locks Bridged) - The control panel may be configured with "Pre-Flight" lift safety enhancement software.

If the lift lies in an unsafe condition due to a short circuit in the safety circuit wiring, trailing cables, terminal connections etc, relative to the door interlock circuitry, Pre-Flight will prevent movement.

For this feature to operate effectively it is imperative that all door and lock status signals are working correctly otherwise unnecessary "lockups" may be experienced.

Note: Pre-Flight is only enabled on controllers with suitable door operators. Please refer to 'Configuration Settings' for confirmation.

3.6.2 Event Logger with Date and Time Recording

The event logger has the facility to store up to 200 events in a queue, together with the date and time the event happened. It is possible to not only interrogate the log for the sequence of events but also to view the occurrences of a specific event and obtain exactly when the event happened and at what floor position, this can be an invaluable aid in troubleshooting and servicing.

When the event log is full, introducing another entry will cause the oldest event in the queue to be lost.

Example of Event Log – Detail screen

It is possible to step through the Event queue with the Up and Down keys to obtain details of the Events, also, by using the Left and Right keys view other occurrences of the same event.

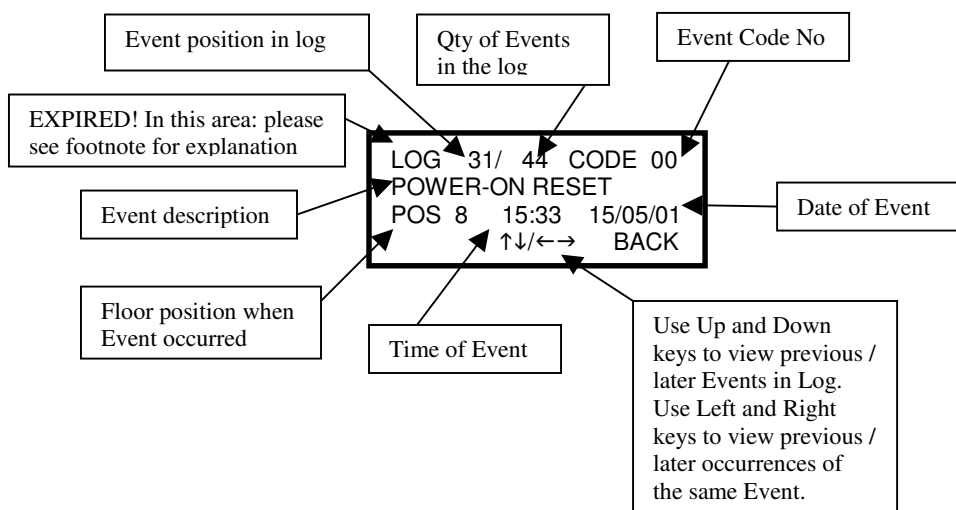

EXPIRED! Means that the old records of the selected event have fallen outside the capacity of the data log, only the last record of the event has been kept for information.

3.6.3 Event Code Description

(N) = Code Number

[EVENT] = As displayed on LCD

(0) [POWER ON RESET]

When the lift is switched on, the Microprocessor Unit (MPU), will begin its reset routine and store it in the event queue and then enter the lift program. The MPU can also be manually reset at any time by operation of the "Reset" Push on the CPU card.

(1) [LOST LAR]

The LAR Relay (Lift Available Relay), on the motor panel provides this signal to the MPU. Whenever LAR Relay is de-energised, for example, due to the stop switch being operated, or the lift switched to maintenance control, the event will be displayed.

The event will remain displayed while this situation continues to exist. All car and landing calls will be cancelled and the 'LSI' (Lift in Service) indicator will be off.

(2) NOT USED

(3) [NOT IN DOOR ZONE]

Here an attempt has been made by the MPU, to pilot open the doors but the "Door Open Contactor" (OC) has not energised. After a short delay and the "Door Zone Input" (MUP) not energised, the event will be recorded and the MPU will then seek another car or landing call elsewhere, to send the lift to.

(4) [D/OPEN PR.T/OUT]

This is when the door has failed to finish opening within 30 seconds. The event will be recorded, the MPU will stop piloting the "Door Open Contactor" (OC) and the "LSI" indicator will be cancelled. After a short delay the MPU will pilot the doors to close, so that the lift may move to another floor.

This fault, for example, could be caused by an obstruction in the landing door track.

(5) [GL LOST : STOPPED]

The lift is idle with the doors closed and with the gate locks made up. If a gate lock is then broken, the event will be recorded. The event will remain displayed while this situation continues to exist. This event can occur through excessive gate lock bounce, or by someone opening a landing door (not necessarily at the same floor as the lift's position).

(6) [GL LOST : HI-SPEED]

Tipping a gate lock on high speed will cause the lift to stop immediately. The MPU will record the event in the log.

After a short delay, the lift will re-start provided that the gate lock has re-made.

(7) [GL LOST : LO-SPEED]

Tipping a gate lock on declaration or slow speed will cause the lift to stop immediately. The MPU will record the event. After a short delay, the lift will try to open the doors, (since it is most likely that the lift was intercepting that floor, in response to a call registered there). If the lift is in the door zone, the doors will open.

If the lift is not in the door zone, a code (3) will be generated. The lift will then re-start provided that the gate lock is re-made and there are calls elsewhere. If the gate lock is still broken a code (5) will also be generated.

(8) [PRE-LOCK FAIL]

In this case, the lift is in the door zone, but unable to move in response to a call because of lock failure. The event will be recorded and the lift will re-open its doors in order to make another attempt to close and make up the gate lock.

After three unsuccessful attempts to start, the lift will then park with its doors open and a code (14) will be generated.

(9) [D/CLOSE PR T/OUT]*

This is when the doors have failed to close within 30 seconds. The event will be recorded, the doors will reverse and park open and all calls will be cancelled. The "LSI" indicator will also be cancelled.

Prior to this situation occurring and if there are calls present, the MPU will reverse the doors if they failed to finish closing within 20 seconds, (without a code "9" generated or call loss etc). Two attempts are made to close within 20 seconds and then the doors will go for the full 30 seconds to close.

Following a door closing protection fault, the doors will park open and will only close again if a car call is operated.

This fault may be caused by an obstruction in the door track, or persons reluctant to move clear of the doors.

Entry of a car call will reset the system.

*Please note that this operation applies to a normal closing cycle only. If the doors are nudging closed under reduced power, they will operate slightly different. Please refer to event 15 (Door Nudging) for details.

(10) [110% OVERLOAD]

Where the input WS110 is active the MPU will record the event, cause the doors to re-open and refuse to close until the load is reduced, also the OLI output (Car Overload Indicator) will be on.

(11) [ENGN'R ATTENDED]

An engineer has added an entry into the Event Log as a marker in the event queue.

(12) [CALL TF'D/CNCL'D]

If the lift has not moved in response to calls present for 45 seconds, landing calls to which it should have attended will be released to the other lift (if one exists), the event is recorded and the "LSI" indicator will be cancelled.

If "[DOOR NUDGING]" feature has been specified, the MPU will sound a "Selfish User Buzzer" discontinuously (if fitted), in the lift car, in order to encourage the occupant to let the lift go.

If the lift still has not moved in response to the calls present for over 100 seconds all car calls will be cancelled. The buzzer will stop and the "LSI" indicator will remain cancelled. If the lift is operating as a simplex, all landing calls will be cancelled as well.

Entry of a car call will reset the system.

(13) [POSITION RESET]

On arrival at terminal floor the MPU has reset its lift position as it does not correspond with that of the top or bottom floor, indicating that the lift was out of step. **It is important that the stepping signal is encountered before the terminal reset signal to avoid false events being recorded. (Not applicable on 2 floor systems).**

(14) [MULT START FAILS]

After three successive pre-lock failures code (8), or three start failures code (21), all car calls will be cancelled, landing calls released, the "LSI" indicator cancelled, and the event recorded.

The lift doors will park open and will only close again if a car or a landing call is operated. If another code (14) is again generated, following a further three unsuccessful attempts to start, the doors will again park open, but will only respond to car calls.

(15) [DOOR NUDGING]

This feature is only available if the door operator is suitable. Provided that there are calls present, limited force door closing will come into operation if the doors are held open for over 40 seconds by safety edge or door open push, or if there have been five door reversals caused by the safety edge, light-ray etc.

A buzzer will sound discontinuously in the lift car, and the doors will close under limited force disregarding safety edge or light-ray operation. (The door open push is still effective in reversing and holding open the doors, but the doors will start closing immediately the door open push is released).

If the doors continue to be obstructed and are unable to close a timer called 'NDT' (Nudge Duration Timer) will operate after 30 seconds and reset the door close routine.

If NDT is required to activate more than 3 times then NDT will be ignored and the following will occur.

The Door Close Protection timer will operate after 30 seconds, the doors will stop attempting to close, calls will be cancelled and Lift Out Of Service will be displayed on the digital indicators. The lift will then only attempt to establish service by entry of a car call.

(16) [RAM FAILURE]

The MPU has found fault with the integrity of its RAM. (Included for completeness).

(17) [STACK ERROR]

The MPU has found fault with its "Book Keeping" and has reset its "Stack Pointer". (Included for completeness).

(18) [SELF-TEST ERROR] MUST BE PRE-CONFIGURED IN SOFTWARE

If the lift has been idle for more than 10 minutes, it will test itself by going to an adjacent floor and returning, seeking a ...(lift moving - lift stopped - doors opening)... sequence of events. If this sequence does not occur within defined time limits, the "LSI" is cancelled. Another attempt is made after a further 10 minutes of idleness for confirmation.

If all is well, no further attempts will be made. If another failure occurs the event is recorded, the doors will park open, and the lift will only try to respond to car calls. The lift will automatically test itself if the lift has been moving or has its doors open or an unusually long time.

Code (18) is also generated if any other condition should cause the "LSI" indicator to illuminate.

(19) [EPROM FAILURE]

The MPU has added up all its program instructions and data and the resultant number does not match with a "Checksum" number also fixed into the program. (Included for completeness).

(20) [SE OVERTIME]

If the lift doors are held open by continuous operation of the safety edge for more than 15 seconds, the event is recorded.

(21) [START FAILURE]

The MPU has signalled for the lift to start and the lift has not done so. After a short delay, the lift doors will re-open and the event is recorded. After three unsuccessful attempts to start, the lift will then park with its doors open and event code (14) will be generated.

(22) [EVENT LOG RESET]

The Event log has been manually reset

(23) - (24) NOT USED

(25) [SIU FAULT]

Please see Bucher fault codes at the rear of this manual. Please refer to Bucher manual for latest revision fault codes.

(26) [LOST CAR PUSH FD]

If the feed to the car pushed is lost, which could be caused by blown CAF fuse, the event is recorded. The lift will run in bus stop routine and be removed from group.

(27) [LOST LDG PUSH FD]

If the feed to the landing pushed is lost, which could be caused by blown LAF fuse, the event is recorded the lift will run in bus stop mode and respond only to car calls.

(28) - (30) NOT USED

(31) [GT LOCKS BRIDGED] (PRE-FLIGHT)

If a gate lock signal is present after the doors have finished opening then the gate locks are assumed to be bridged.

In this event several things occur:

- i) Lift movement on normal service is inhibited
- ii) Landing, Car and Homing calls are cancelled/disabled

- iii) Service control and Prepare to test feature are all disabled
- iv) Emergency recall is disabled
- v) Fire service is disabled, if not already operating in phase II mode. If phase II is active then the PRE-FLIGHT check is disabled
- vi) During dormant parking on hydraulic systems the PRE-FLIGHT check is disabled.

(32) NOT USED

(33) [LTLR TIMEOUT]

If during the slowing cycle the lift has taken an excessive time to obtain floor level the MPU will cause the direction to be lost, thus stopping the lift, the event is recorded and the lift will be reset by a car or landing call or MPU reset. (If nuisance tripping occurs check value of LTLR timer setting.)

(34) [LEVELLER ERROR]

If during running the MPU considers a proximity/relay contact in the levelling circuit to be operated at a time when it should not be operated, or if operated in an incorrect sequence, or if two attempts at re-levelling have occurred, both exceeding five seconds and without the relevant proximity/relay contact being operated. The event is recorded and advance door opening/re-levelling will be inhibited. The DOP will remain operative provided the lift is in a door zone.

(35) [DRIVE ERROR]

This signifies that a manual reset device has tripped (i.e. DJR or MOL) and that power has been removed from the motor circuitry on the controller. The MPU will initiate a downwards dive. Once at the bottom floor the lift will park with its doors closed after allowing any passengers to alight. The DOP will remain operative in all instances providing the lift is in a door zone.

(36) [STUCK CAR CALL]

If one car push is not released within the expected time, it will be presumed stuck. The call will be ignored in future until it is released and reinserted, the fault is recorded along with the floor level that is affected.

(37) [STUCK DOWN CALL]

Similar to (36) except the call is a down landing call.

(38) [STUCK UP CALL]

Similar to (36) except the call is an up landing call.

(39) - (41) NOT USED

(42) [*TEST CONTROL*]

Indicates that the control system is in "Test control mode", i.e. Car top control or Panel test. During this time no calls will be accepted and all features such as Fire or Service control are disabled.

(43) [MULT LEVEL ERROR]

The LU, LD and DZ (MUP) inputs are monitored by the MPU, if an incorrect signal is detected an event 34 LEVELLER ERROR will be logged. If event 34 occurs on three consecutive journeys to the same floor this is considered to be a MULTIPLE LEVELLER ERROR and indicates a problem with the magnet set-up at a particular floor. The MPU will initiate a downward dive. Once at the bottom floor the lift will park with its doors closed after allowing any passengers to alight. The DOP will remain operative in all instances providing the lift is in a door zone. The system can be reset by pressing the (ACK) push button once the fault has been investigated and resolved. The check is performed on each run.

(44) [MULT HEAD ERRORS]

The LU, LD and DZ (MUP) inputs are monitored by the MPU, if an incorrect signal is detected an event 34 LEVELLER ERROR will be logged. If event 34 occurs on three consecutive journeys this is considered to be a MULTIPLE HEAD ERROR and indicates a fault with the tape head device. The MPU will initiate a downward dive. Once at the bottom floor the lift will park with its doors closed after allowing any passengers to alight. The DOP will remain operative in all instances providing the lift is in a door zone. The system can be reset by pressing the (ACK) push button once the fault has been investigated and resolved. The check is performed on each run.

(45) [RELEVELLING ERROR]

This event is recorded if the lift has failed to reach true floor level in the allotted time or number of attempts. This event will be logged in association with event 34 [LEVELLER ERROR] as a means of further isolating a fault.

(46) – (50) NOT USED

(51) [LIGHT DUTY]

This event is recorded after heavy duty or peak duty has finished, to indicate the system is back to normal.

(52) – (56) NOT USED

(57) [RTC CLOCK CHANGE]

If the user makes adjustment to the RTC this event will be recorded with the new time and date setting.

(58) [RTC REGS UPDATE]

The MPU has found corruption within the real-time clock data register and has rectified the error, however some events may have recorded bad time and date data or may not appear in chronological order.

(59), (60) NOT USED

(61) [EMERGENCY RECALL]

Indicates that the system is in EMERGENCY RECALL mode. This requires an external input, to call the lift to a predetermined floor (usually main). The lift will return to the floor ignoring all calls and shutdown, after allowing any passengers to alight the doors will park open or closed depending on customer specification at time of order.

(62) [LEVELLER/DIR ERR]

If the LU/LD/MUP signals are received by the MPU in an incorrect sequence, the event is recorded and at what level.

The event may also be triggered if the LU/LD overlap is incorrect.

(63) NOT USED

(64) [THERMISTER TRIP]

If the motor room temperature sensor detects an excessive temperature the lift will respond in the following manner. On Normal Service the lift will stop at the next floor without opening its doors, then return to the bottom floor and open its doors.

On Fire Service the lift will stop at the next floor and remain there with its doors closed. On Special Service the lift will stop at the next floor and remain there with the doors open.

(65) [RTC CLOCK ADJUST]

If an invalid time or date is detected within the real time clock RAM due to corruption, the event will be recorded and the time and date set to a default of 1/1/99 00:00.

(66) [OIL OVER TEMPERATURE]

If the oil sensor detects an excessive temperature the lift will respond in the following manner. On Normal Service the lift will stop at the next floor without opening its doors, then return to the bottom floor and open its doors.

On Fire Service the lift will stop at the next floor and remain there with its doors closed. On Special Service the lift will stop at the next floor and remain there with the doors open.

(67) NOT USED

(68) [FIRE ALARM RECALL]

As Fire Service the lift will stop at the next floor and without opening its doors return to the fire floor. The doors will open and dwell closed or remain open (specify at time of ordering). No car or landing calls can be entered.

(69) [LANDING INHIBIT]

Door disable or Prepare to test activated.

(70) [*FIRE SERVICE*]

Indicates that the system is in Fire Service mode. See section 3.4.3 for further information.

(71) [*SPECIAL SERVICE*]

Indicates that the system is in Special Service mode. See section 3.5 for further information.

(72) [DESPATCH FAILURE]

This event will be recorded if the car enters bus-stop mode i.e. when the lift is in service, LPF or CPF are lost and homing is enabled. Bus stop mode will automatically enter calls at alternative floors to give a limited lift service. To switch off the feature, disable Homing (see 3.3.1 SW2)

(73) [TOP FINAL LIMIT]

Indicates that the top final limit switch has been operated which disconnects the power to the control circuit. When the switch is remade and power returned the MPU returns the lift to the bottom floor and shuts down. To be reset by pressing the [ACK] pushbutton, provided the lift is in door zone at the bottom floor. The DOP will remain operative provided the lift is in a door zone.

(74) [LSC MONITOR ERR]

The LSC output is monitored via the MDN input. The output allows movement whilst the doors are open, for re-levelling purposes, or allows advance opening. If the monitored input is on when not expected then this constitutes an error, the MPU shuts down. To be reset by pressing the [ACK] pushbutton. The DOP will remain operative provided the lift is in a door zone.

(75) – (81) NOT USED

(82) [PWR ON MEM TEST]

The MPU had detected a data error in memory during power up and reset default values.

(83) [RUN MEM TEST]

The MPU had detected a data error in memory while the program was running and reset default values.

(84) – (89) NOT USED

(90) [COUNTERS RESET]

The Journey and Door Counters have been reset to 0,000,000

(91) [LCD OVERFLOW ERROR]

The system has detected an error in the LCD screen data.

(92) [LCD INIT FAILURE]

The system has detected an error with the LCD display during power up.

(93) [SETTINGS MENU ENTRY]

The system has recorded entry into the Settings Menu from the secure password entry screen.

(94) [CONFIG MENU ENTERED]

The system has recorded entry into the Configuration Menu from the config password entry screen.

(95) [SETTINGS PWD ALTERED]

The system has recorded that the 'Settings' security password has been changed.

(96) [CONFIG PWD ALTERED]

The system has recorded that the 'Config' password has been changed.

(97) [FACTORY DEFAULTS]

All parameters have been reset to factory default values, this includes, Event Logs, Timers, Passwords and Feature Settings, (all data that is viewed / accessed through the LCD display).

(98) [SHADOW SET]

The shadow RAM has taken majority verdict, (used for internal data monitoring only). If event is recurring please refer to factory.

(99) [EEPROM BUSY]

Generation of this event indicates a read or write failure of the on-board serial EEPROM device. Recurring faults of this nature may indicate a CPU board hardware failure that may require replacement of the processor board to remedy.

3.7 **COUNTERS**

There are two counters built in to the MMI as standard.

[JOURNEY COUNTER]

The journey counter increments by one each time the lift starts in either direction giving a total journey count since installation, this can be useful to take note of during maintenance.

[DOOR COUNTER]

The door counter increments by one each time the doors open or close giving a total count of door operations since installation, this can be useful to take note of during maintenance.

3.8 **CALLS**

It is possible to enter Car calls, Up and Down landing calls via the MMI without the need of link wires that could inadvertently cause damage to the microprocessor.

[CAR CALL ENTRY]

Selecting this will take you to a CAR call entry screen, the calls will only be shown for the levels available. i.e. only 4 calls will be shown on a system configured for 4 floors. Please note calls can only be entered through the MMI that are available in normal use, any levels that have been secured will not respond. Calls can be inserted or removed by toggling the level required, (a hollow square represents no call entered; a solid square represents a call registered).

[UP CALL ENTRY]

Selecting this will take you to a UP Landing call entry screen, the calls will only be shown for the levels available, i.e. only 4 calls will be shown on a system configured for 4 floors. Please note calls can only be entered through the MMI that are available in normal use and normal service, any levels that have been secured will not respond. Calls can be inserted or removed by toggling the level required, (a hollow square represents no call entered; a solid square represents a call registered).

[DOWN CALL ENTRY]

Selecting this will take you to a DOWN Landing call entry screen, the calls will only be shown for the levels available, i.e. only 4 calls will be shown on a system configured for 4 floors. Please note calls can only be entered through the MMI that are available in normal use and normal service, any levels that have been secured will not respond. Calls can be inserted or removed by toggling the level required, (a hollow square represents no call entered; a solid square represents a call registered).

3.9 **SETTINGS**

The ONIX Evolution has many features that can be configured through the MMI that makes the ONIX control system more flexible, with the ability to change site related settings without the need of changing the main program EPROM.

The options available can be found in the 'SETTINGS' menu and are secured behind a password code before adjustment can be made, details of the features are detailed below. **(Please see 3.5.2 for menu overview)**

3.9.1 **Date and Time**

The Date and Time used for Event logging is adjustable through the MMI, the Date and Time will normally be factory set and should not need setting, however, it may be necessary to reset if the CPU board is changed or data corrupted. There is also the option for automatic date adjustment for British Summer Time which can be disabled if required.

3.9.2 Timers

User adjustable timers are accessed through the MMI.

To view or adjust timer settings it will be necessary to enter the Settings Menu and enter a security password. **Please see 3.5.2 for details.**

Once the Timers selection is made the following screen will be found:

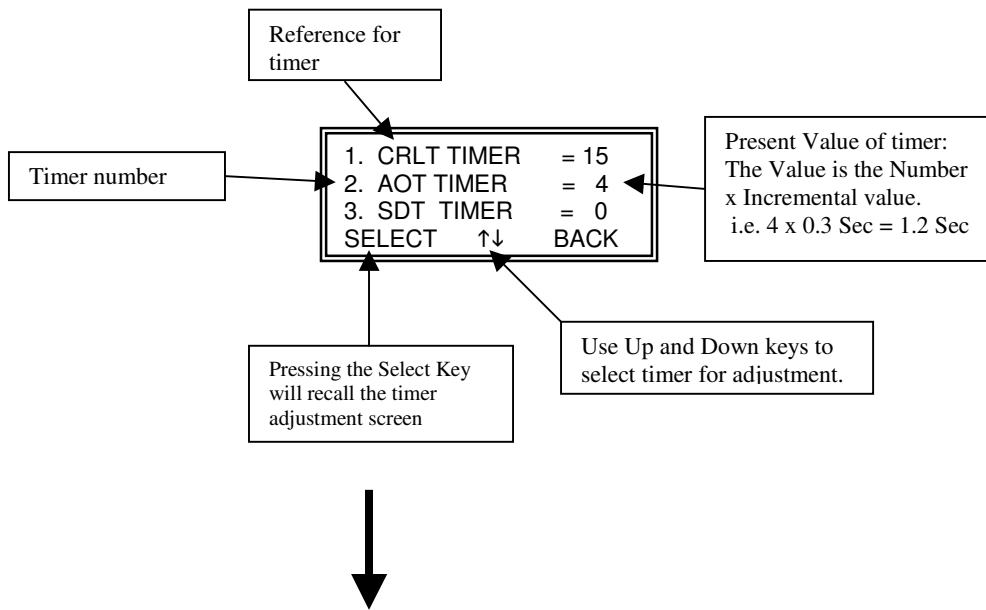

Selecting the timer will take you to the adjustment screen; an example is given below for the AOT timer.

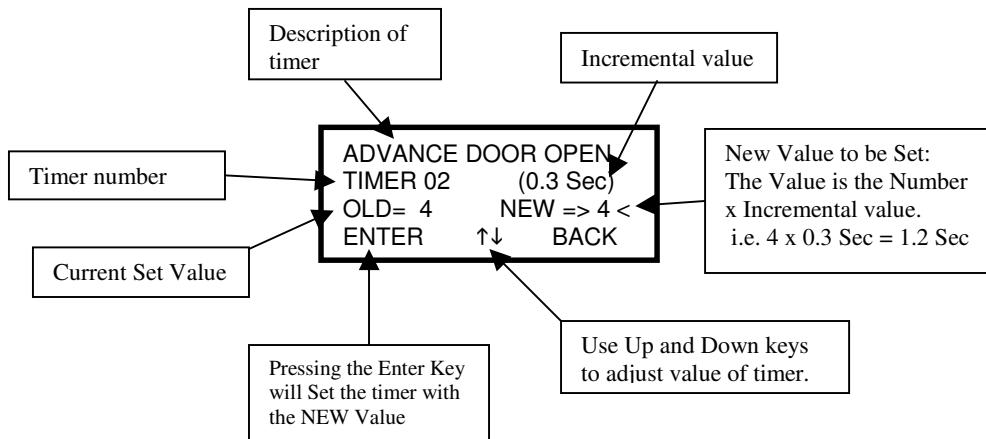

For details of all other timers please see 3.9.2.1 Timer Settings.

3.9.2.1 Timer Settings

NO	TIMER REF	DOOR TYPE	DRIVE TYPE		FUNCTIONS	RANGE	INCREMENT	DEFAULT SETTING		REMARKS
			HYD	HYV				VALUE	DELAY	
1	CRLT	N/A	✓	✓	Car Light/Fan Control	1 - 15m	1.0m	15	15m	Starts timing from the end of the last journey regardless of the reason for that journey
2	AOT	AUTO	✓	✓	Advance Door Open (0 = Disable)	0 – 4.5s	0.3s	4	1.2s	Closed Loop Only
3	PMD	N/A	✓		Pump Motor Delay	0 – 3.0s	0.2s	5	1s	Hydraulic Only
4	1SR	AUTO	✓	✓	Door Re-Open Delay	0 – 1.5s	0.1s	6	0.6s	A.C. Doors only
5	LTLR	N/A	✓	✓	Low Speed Time Limit	4 - 30s	2.0s	7	14s	
6	LDDT	AUTO	✓	✓	Landing Call Door Dwell	0 - 15s	1.0s	7	7s	
7	CDDT	AUTO	✓	✓	Car Call Door Dwell	0 - 15s	1.0s	3	3s	
8	DRHD	AUTO	✓	✓	Door Hold Timer	0 – 5m	10.0s	12	2m	
9	HOME	N/A	✓	✓	Homing Delay Timer	2 - 120s	1.0s	30	30s	
A	ELRV	N/A	✓	✓	Hydraulic ELRV Soft Brake (Down)	0.5 – 2.0s	0.1s	10	1s	
B	RLVU	N/A		✓	Relevel Delay Up	0 – 1.0s	0.1s	5	0.5s	Delays dropping of LSR output upon receiving LD following a relevel
C	RLVD	N/A		✓	Relevel Delay Down	0 – 1.0s	0.1s	5	0.5s	As above but LU, not LD
D	MFRT	N/A	✓	✓	Multi Floor Run, Position Trigger Delay Time	0 – 4.5s	0.3s	0	0s	
E	SFRT	N/A	✓	✓	Single Floor Run, Position Trigger Delay Time	0 – 4.5s	0.3s	0	0s	

Notes 1) REFER TO MAIN CONTRACT DRAWINGS FOR APPLICATION
 2) ✓ = USED ON DRIVE/DOOR TYPE

3) SEE KEY TO ABBREVIATIONS
 4) THE FUNCTION MAY VARY IN SPECIAL CASES

KEY

DRIVE TYPE

HYD HYDRAULIC
 HYV VVVF HYDRAULIC

DOOR TYPE

AUTO ONLY USED FOR AUTOMATIC POWER DOORS

3.9.3 Return and Recall

This feature allows the facility to configure the level for the 'Fire Return', 'Emergency Recall' and 'Main Floor' for homing purposes. Please note: on Duplex systems the main floor must be set to the same level on both panels.

3.9.4 Door Settings

This feature allows the facility to configure the number of door reopens allowed when the lift has committed direction. The main floor can be set independently of all other floors.

3.9.5 Feature Settings

There are a number of options available for configuration to suit the site requirements, the options available are detailed below.

- **[DIR ERR CHECK]**

This feature uses the levelling signals to detect actual direction of travel if no other means of direction feedback is available, this feature is used for 'Open Loop' applications.
- **[ALTERNATIVE LOSI]**

This feature enables an alternative set of rules for the 'Lift Out of Service Indicator'. In addition to the normal conditions that trigger the LOSI, the additional conditions that are included in the alternative LOSI are:
Fire Service, Special Service (Car Preference) and Emergency Recall.
- **[NORM CLOSE RESETS]**

The terminal floor position resets can be configured in two modes, 'Normally Closed' contacts which is the TVC default standard, can be changed to 'Normally Open' contacts if required.
- **[FIRE RECALL PARK OP]**

This feature gives the option for the doors to park open or closed following a Fire Alarm Recall.
- **[FAM FCI ENABLE]**

This feature enables/disables the usage of FCI output on fire alarm recall.
- **[EMR RCLL PARK OP]**

This feature gives the option for the doors to park open or closed following an Emergency Recall.
- **[BINARY INDICATORS]**

This feature changes the position indicator outputs from discrete outputs (one per floor) to Binary format, this must be configured correctly to suit the type of position indicator / encoder / speech unit being used.

- **[BIN IND BOTTOM 0]**

In conjunction with the above some Binary encoded indicator / speech units utilise 0 as position 1 while others utilise 1 as 1, this option allows the panel to be configured to suit either.

- **[NORM CLOSED WS110]**

The 110% input from the Weight Switch can be configured in two modes, 'Normally Open' which is the Liftstore default standard, can be changed to 'Normally Closed' if required.

- **[POS TRIG POLARITY]**

The position trigger output to the speech unit (defined elsewhere) has two modes of operation. A positive edge trigger, which is the Liftstore default standard, can be changed to a negative edge trigger if required.

- **[INH. LSI ON TEST]**

This feature inhibits the 'Lift out of service' indicator when the panel is under Car Top Test control.

- **[WINTER AUTO TEST]**

This feature allows the lift to run to the top floor if it has remained idle for a period of 30 minutes or more.

3.9.6 Floor Settings

There are a number of options available for floor configuration, it is possible to secure floors from lift service and to adjust the single floor run slow points. Details of the options are given below.

- **[SECURE LND CALLS]**

It is possible to secure any floors from Landing Calls, this may be used on a temporary or permanent basis, for instance a change in building use or building works. The floors can be secured / unsecured by toggling the level on the screen, (a hollow square signifies unsecured, a solid square signifies secured).

Note: If a floor is secured it is not possible to enter an Up or Down Landing call via the MMI.

- **[SECURE CAR CALLS]**

It is possible to secure any floors from Car Calls, this may be used on a temporary or permanent basis, for instance a change in building use or building works. The floors can be secured / unsecured by toggling the level on the screen, (a hollow square signifies unsecured, a solid square signifies secured).

Note: If a floor is secured it is not possible to enter a Car call via the MMI.

- **[LOWEST LEV DUPLEX]**

This facility is to be used on Duplex applications when the bottom levels served are not equal, the lift that travels to the lowest level should also be set as the 'Master' lift. Please see 3.3.1

Warning: If the lowest level duplex setting exceeds any of the return and recall settings then that feature will no longer work e.g. fire control, emergency recall, homing.

3.10 CHANGE PASSWORDS

The controller leaves the factory with default passwords installed (details can be found in 3.5.2). These numbers can be changed to the customer's choice if required for additional security against parameter changes.

3.11 SOFTWARE VERSION

The controller is fitted with a specific version of software to suit the controller type; the software version can be viewed on this screen for information purposes. It may be useful to note the version when contacting the factory for technical support.

3.12 CONFIGURATION

The configuration section is primarily for use by the factory for configuring the microprocessor to suit the panel design and application. There should be no reason for this section to be entered by the customer therefore no further detail is being given.

For information; the options available in this section are shown in the 'Overview of Menu System' but no attempt should be made to adjust settings without contacting Customer Service at TVC as this may impair the operation and Warrantee of the controller.

4.0 TECHNICAL DESCRIPTION

4.1 MOTHERBOARD (FIG 1.0)

The Motherboard contains sockets to mount the plug-in boards:

1. Processor
2. I/01, I/02, I/03

It also contains the Control Inputs and Outputs to the Panel, the Double journey Relay and external terminals.

4.2 POWER SUPPLY

The Power supply Module is mounted directly on the top of the mains transformer to conserve panel space. AC voltages are connected directly from the transformer into the PSU module where they are fused, rectified, filtered and fused again. Each output of the PSU has an LED to indicate that it is operating correctly.

The Output Voltages of the PSU module are as follows:

- +10vDC Input to the 7805 + 5v regulator on the Motherboard supplying power to the Microprocessor Logic circuits.
- +24vDC Power for the relays on the I/O Cards etc.
- +100vDC Power for the External Input signals

PSU Module Fuse Values (All fuses are 20mm)

9Vac	2A	Anti-surge
19Vac	3A	Anti-surge
75Vac	1A	Anti-surge
+10Vdc	1A	Quick-blow
+24Vdc	2A	Quick-blow
+100Vdc	500mA	Quick-blow

4.3 CPU CARD (CENTRAL PROCESSING UNIT)

The CPU Card contains the 6809 Microprocessor, RAM, EPROM and all support circuitry. It also contains the configuration switches and PTT (prepare - to - test) and DDS (door disable) switches.

4.4 WATCHDOG – LOOP FLAG MONITOR

The end command of the main lift program instructs the MPU to go back to the start of the program, this loop continues servicing all the routines and signifies correct operation of the system. A Counter counts the number of loops completed and causes the LOOP FLAG indicator to flash.

If in any event the MPU stays in a particular routine, the LOOP FLAG indicator discontinues flashing and the fault is recognised by the LOOP FAILURE MONITOR which will reset the MPU, and cause it to re-enter the loop (EVENT CODE '0').

4.5 AUDIBLE WARNING

A warning bleep will occur in conjunction with the EVENT CODE display, whenever an event occurs in the microprocessor system.

4.6 PUSHBUTTONS

Six pushbuttons, are situated on the front of the MMI which are used for adjusting timers, parameters and re-calling events which have occurred within the system and other special functions.

5.0 OVERHAUL & REPAIR

5.1 HANDLING OF EPROM'S

WARNING EPROM'S ARE DEVICES WHICH REQUIRE CAREFUL HANDLING IN THE REMOVAL AND INSERTION STAGE, AS THEY CAN EASILY BE DAMAGED BY STATIC ELECTRICITY.

To change EPROM - see instructions in back of this manual.

5.2 FAULT FINDING PROCEDURES

Initial Checks

- 1) Ensure all power supplies on MPU are operating satisfactory.
 - a) 100V dc supply LED illuminated on power board
 - b) 24V dc supply LED illuminated on power board
 - c) 10V dc supply LED illuminated on power board
 - d) +24V supply LED illuminated on Motherboard
 - e) +5V dc supply LED illuminated on Motherboard.

If the power supply LED's are extinguished, check the fuses on the power supply card (situated in holders mounted on the card). If fuses persist to blow, remove all cards and reinsert one card at a time until fault is localised to a card which can then be replaced.

- 2) Check loop flag is pulsing on CPU card proving that the MPU program is continually scanning its programme loop.

If this condition cannot be achieved then the CPU card should be replaced. Remember when replacing the card that the EPROM contained on the original card must be moved into the test replacement card, (EPROMS must have labels with contract details covering a transparent window, label must not be removed). If satisfactory operation of the loop flag indicator is not achieved then replacement EPROMS must be tried, and closer monitoring of the power supplies must be carried out, this time with a meter.

- 3) Having achieved pulsing operation of the loop flag attention should be turned to the I/O cards.

- 4) With all cards inserted into the motherboard the lift should be ready for initial operation.

Switch the lift to car top test and observe the LED signals on the I/O cards. Check that the selected I/O signals are "ON". If LED's are not as expected, then check voltage to terminals at inputs to motherboard to verify that external signals are correct. If I/O card LED's do not coincide with input terminal voltages then wiring should be checked or cards replaced to isolate fault.

- 5) Door open and close operation on normal service is controlled by output signals DOPR and DCLR respectively. With doors closed DCLR, GL and LU/LD/MUP if in door zone, should be illuminated. Operation of SE or DOP signal on normal service should operate DOPR signal to open the doors providing LU/LD/MUP signals are present (lift in door zone). When doors open first GL and then DOL are extinguished. If lift is on normal service then after approximately seven seconds (adjustable by LDDT dwell timer) the doors should park closed.

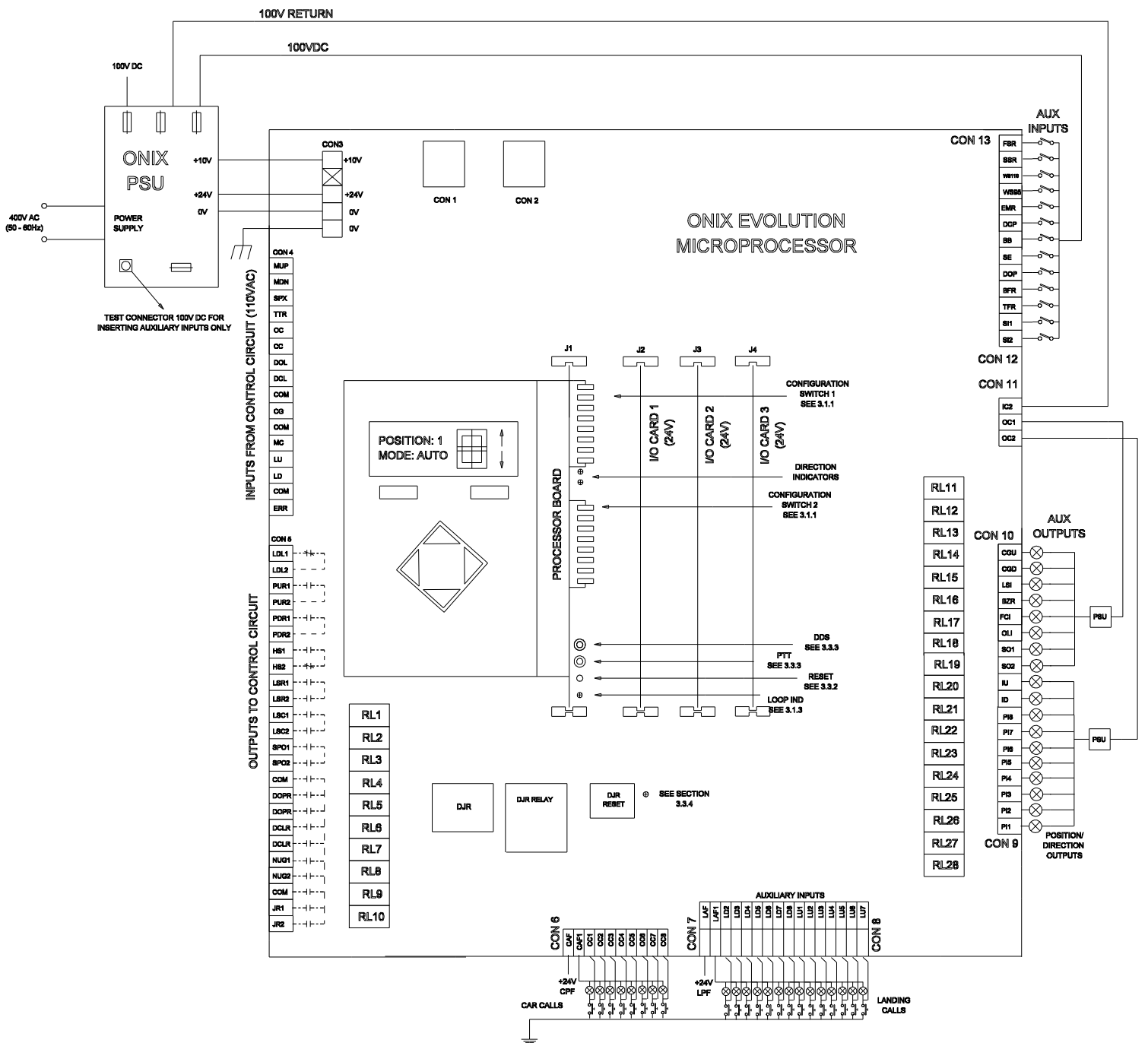

EPROM CHANGING INSTRUCTIONS

Severe electrical transient voltages can be generated during handling. These static voltages are ruinous when discharged into electrical components, i.e. EPROMs. Nylon or other static generating materials must not come in contact with EPROM devices and personnel should discharge themselves to ground prior to handling. Both Eproms IC8 & IC22 will need to be changed in the following manor:

1. Switch controller power supply OFF.
2. Remove the Onix CPU board from the Motherboard taking care not to damage the connector pins. To achieve this you must first remove the LCD panel from the motherboard via the front screws and pillars (Figure 1). Note the LCD panel and CPU board slide out together.

Figure 1. LCD Panel.



Note the 4 Screws on the LCD Panel's face. These have to be removed to get to the lower pillar screw underneath. The lower pillar screw must then be removed.

3. Remove the existing EPROM IC8 with a small screwdriver blade under one end of the pin socket. Ease it carefully, until it is nearly out of the board DIL sockets. Then grasp the EPROM with as many fingers in contact with as many pins of the EPROM as possible and transfer it straight to anti-static foam. Similar care should be taken when inserting the replacement EPROM onto the board DIL socket.
4. Fit the new EPROM ensuring that the notch is in the correct position according to Figure 2 below.
5. Replace the Onix CPU board with care, make sure all pins are lined up with the connector before pushing the board into position, then switch controller supply ON.

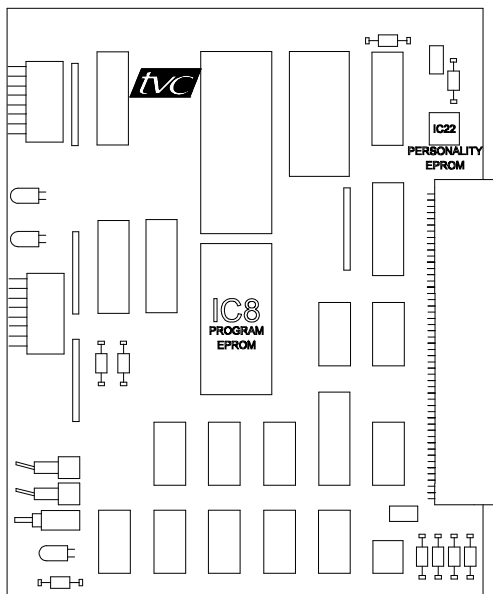

Figure 2. Onix CPU Board

Replacement Software

IC8 contains the program & IC22 contains the personality setting configured by the menu system. If Contract consists of multiple like panels (e.g. Duplex), ensure that all software supplied is fitted so both panels contain the same program release. Failure to do so may result with intermittent problems.

Note

If the Eprom's are being transferred to another board because of a faulty board, ensure both IC3 & IC22 are transferred. Whilst carrying out this procedure care must be taken not to upset the switch settings of SW1 and SW2. It is recommended that the positions of these switches be recorded before undertaking this procedure.

7.0 ADDENDUM

7.1 BUCHER FAULT CODES

Miniterminal	Display		Cause	Remedy
	Handterminal			
1		Err:Current	Solenoid current exceeds 1.3A <ul style="list-style-type: none"> • Wiring fault, short circuit between terminals 6a/7 or 6b/8 • Solenoid coil is defective 	<ul style="list-style-type: none"> • Correct the wiring fault • Fit a new solenoid coil
2		Err:El. Temp. Err:Board-T	Temperature of DELCON exceeds 70°C <ul style="list-style-type: none"> • Ambient temperature is too high • Poor ventilation in control cabinet 	<ul style="list-style-type: none"> • Lower the ambient temperature • Improve control cabinet ventilation
3		Err:Input Err:Input-V	Supply voltage less than 17V or more than 41V <ul style="list-style-type: none"> • Mains voltage is too low or too high • Incorrect power supply unit for the DELCON (transformer code 280-G21 / 281-G21 / 282-G21) 	<ul style="list-style-type: none"> • Check the incoming mains voltage • Choose the correct power supply unit to suit the mains voltage • Replace the power supply unit
4		Err:Output Err:Temp-amp	DELCON output stage is defective <ul style="list-style-type: none"> • There is a fault in the DELCON 	<ul style="list-style-type: none"> • Replace the DELCON
5		Err:SIU-1	Demand/Feedback difference too large <ul style="list-style-type: none"> • SIU demand/feedback monitoring (LED lights up) • Acceleration is too high • Fast DOWN is set too high on the DELCON • Flow rating of pipe rupture valve is too low 	<ul style="list-style-type: none"> • The DELCON settings are too low • Decrease the acceleration setting • Decrease the fast DOWN setting • Decrease the fast DOWN setting
7		Err:Command	Incorrect combination of commands <ul style="list-style-type: none"> • E.g. Up and Down simultaneously • Stop during fast travel 	<ul style="list-style-type: none"> • Ensure correct commands are signalled
8		Err:Zero point	Null point outside of ± 1.00V <ul style="list-style-type: none"> • Mechanical null point is wrongly set • Bypass pressure is too high 	<ul style="list-style-type: none"> • Reset the mechanical null point • Bypass screw 2 on the valve is set too high, readjust

7.2 ELRV VVVF TIMING SEQUENCE

UP JOURNEY

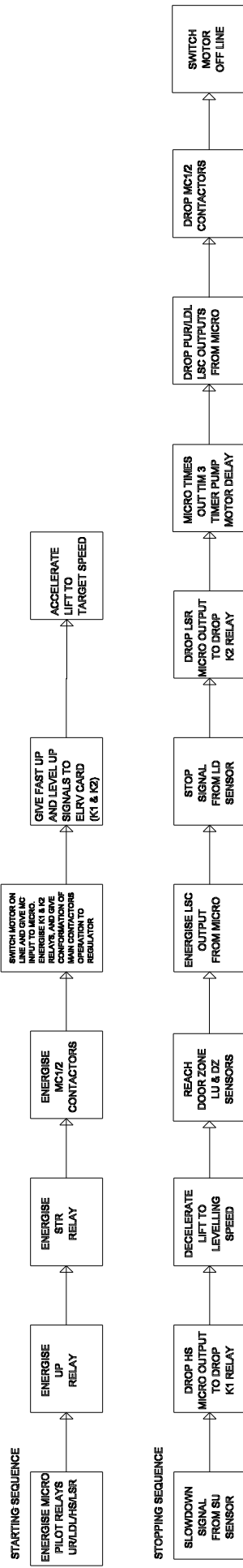

DOWN JOURNEY

