

HW03 Handwind Node Board Installation Sheet

We reserve the right to alter, without giving prior notice, technical data, dimensions and weights described in this manual.
 Thames Valley Controls Ltd. Manor Farm Industrial Estate, Flint, Flintshire CH6 5UY
 (t): +44 (0) 1352 793222 (f): +44 (0) 1352 793255



Handwind Node
 TVL365 ISSUE 2

Introduction

The HW03 Handwind unit is a unit for displaying lift floor level for handwinding purposes. The unit should be mounted close to the lift machine so the person handwinding has visibility of the floor position when moving the lift.
Caution:- Electrically isolate the lift controller if handwinding is to be carried out. The unit will display Handwind Mode when isolated.

Precautions

Observe normal precautions for handling electronic devices, avoid static electricity, dampness and extreme temperatures.
 Please read this instruction sheet fully before use.
 The unit is to be wired as per the relevant panel drawings.

HW03 Modes of Operation

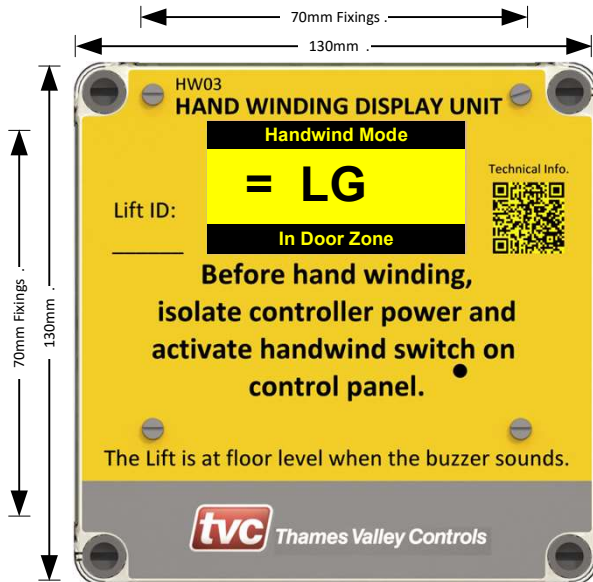

Internal PCB Layout (Rear)

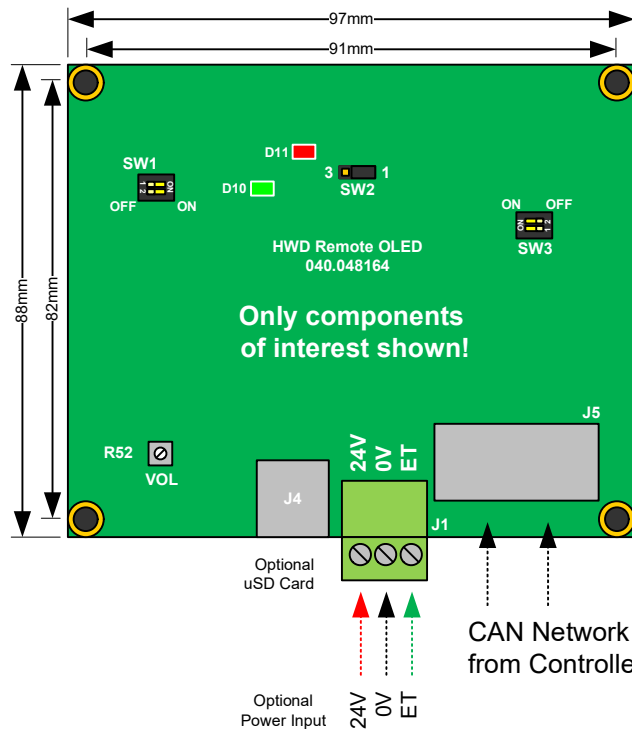

Specification

Supply Voltage 24 V d.c.
 Board Operating Current 40mA

Level Legends

The level legends can be adjusted via the Ethos Two MMI.
 Press the "Indicators and Speech" button on the main screen and then select Floor Legend, use the index arrows to select the floor and then edit the floor legend characters. The character limit is 2.

DIP Settings

SW1		DIP	Name	Both DIPs off = Normal / Running Mode.
ON	1	2	Test Dip Bit 1	DIP 1 on only = Demo Mode.
	2	1	Test Dip Bit 0	DIP 2 on only = Functional Test. DIP 1 and 2 on = Display Test.

SW3		DIP	Name	DIPs 1 and 2 on for CAN termination
ON	1	2	CAN Term	These should only be set on the last node in the network. (optional)
	2	1	CAN Term	

Jumper Settings

SW2 Place Jumper in the 1-2 position for normal operation.

Volume Adjustment

The HW03 Handwind Node board comes with built in buzzer to confirm floor level. For volume adjustment turn potentiometer R52, clockwise to increase volume and anti-clockwise to lower the volume.

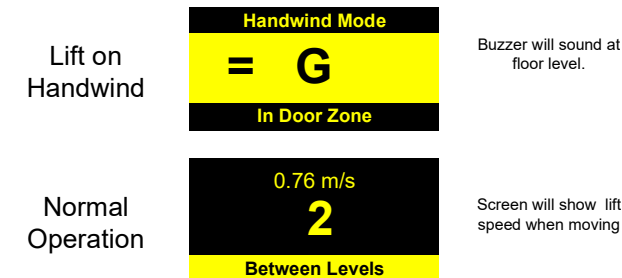

Screen Saver:- If no activity is seen from the lift for over 2 hours the unit will enter screen saver mode. The screen will alternately be blank, show the logo and then show the normal or hand-wind screens. (Software Ver2.02 and above)

Loop and Fault LED's

The Green LED (D10) will flash every 2 seconds to signify power to node and that the node is running.

The Red LED (D11) will light continuously for 4 seconds when the node is first powered up. After this point the red LED signifies various fault codes. The LED will flash every 4 seconds if the node has a fault.

Red Network Debug LED

- 1 flash every 4 secs = Node not communicating with Ethos.
- 2 flashes every 4secs = Node is experiencing data bus faults.
- 3 flashes every 4 secs = Node has stopped transmitting due to bus faults.
- 4 flashes every 4 secs = Node has stopped transmitting or receiving from the data bus

INTRODUCTION

This Manual is to be read in conjunction with Ethos 2 Quick Start Manual (TVL350) It is important that you familiarise yourself with both manuals before commencing any work with the Ethos or the Ethos 2 serial system. Be aware that the lift panel will contain equipment that is supplied with potentially lethal voltages. Please make sure the panel is isolated before carrying out any installation work or modifications. The TVC Ethos 2 Serial System is a distributed field-bus network for interfacing calls and I/O to an Ethos 2 lift controller. The system is used in place of normal discrete wiring for calls and car related input and outputs. Instead of each push and call lamp being directly connected to the panel, in the motor room, they are can be connected to local PCB's or nodes that are distributed about the car and lift shaft. This will depend on particular installation requirements.

BASIC SETUP GUIDE

This basic guide is designed to give an outline of installation and set up of a Ethos 2 serial system. Please refer to relevant installation sheets for more in depth information.

Machine Room

Install main panel. Make sure the routing of any mains or motor cables are kept away from the network cables.

Connect the car network from the trailer to terminals as shown on the panel drawings. Make sure screens from the trailer are earthed, as the drawings show.

If fitted connect up the shaft network to the power feed board and then if applicable connect this to the other controllers in the group.

Once wiring has been completed and checked follow the standard Ethos 2 power up routine.

Make sure all nodes are present in the view I/O screens of the MMI. All nodes can be tested by activating inputs or call pushes and seeing the result appear on the MMI view I/O screens.

Lift Car

The car related boards may be mounted in the car push station or in the terminal box on the car top.

Wire in all car pushes and acceptance lamps plus optional features inputs and outputs as per wiring diagrams.

Configure car module for front or rear operation. Configure the call expansion boards and I/O boards as shown on the controller diagrams.

Connect all nodes together with supplied patch cables, as per the drawings. The final board in the chain should have its network termination DIP's switched on, again make sure these are only active on one node on the car / panel network.

Plug the first board on the car top into the relevant trailer connections.

The screens from the trailer cores must be earthed at the panel end of the trailer only, as per the diagrams.

Lift Shaft

Mount optional Landing Nodes in the shaft, either in the push back boxes or in a suitable plastic box mounted close to the push station.

Each Landing node has a unique ID this should be set as per the controller drawings, make sure the nodes are installed at the correct landings.

Connect Landing pushes and acceptance lamps to nodes, make sure wiring is correct 3-wire system.

Connect each landing node to the next one in the shaft, using the supplied patch cables.

Connect terminator boards, if applicable, to the ends of the landing networks. Warning: a maximum of 2 terminators should be fitted to this network in total.

Connect landing node network back to the Power Feed Board on the Ethos 2 controller.

If the optional landing network is not fitted provision for wiring landing calls will be made within the panel on call expansion modules.

FAULT FINDING PROCEDURES

Fault Finding Within a System

With power applied to the system check that all nodes have their green LED's flashing. If the green LED's are not flashing check the power supply on the power feed board.

Check solutions screen and active events in the Ethos 2 for any relevant problems

A network failing to respond on power up would be caused by :

Incorrect or broken wiring connection on the network.

No nodes connected to the network.

One or both of the network power supplies not working or connected.

None of the nodes configured correctly.

If a network has failed to respond to commands sent out by the Ethos 2 then repeated tries will be made to establish communication. When the network connection is established this is also reported as an event in the Ethos 2 event log.

System checks

After testing an installation as described above and having no response to calls placed in the system the following need to be checked:

That the panel is on normal mode.

The DIL switches are set correctly on all boards and termination boards and termination DIL switches are fitted where necessary.

All network connections are connected to the correct terminals.

Both networks are connected to the panel connections. (If landing network fitted)

The car and landing networks are not swapped over. (If landing network fitted)

Check that the green LEDs' on both Car and Landing nodes are flashing

Check nodes for red fault LED's. see relevant board installation sheet for description.

If the green LEDs' fail to illuminate then the 24 volt supply is not connected to the node

Check external feeds to the car boards

If all of the above are correct then the networks should function correctly.

EMC GUIDELINES

It is extremely important that the following guidelines are adhered to.

All bus runs must be kept away from motor wiring, a separation of at least 300mm.

Keep bus wiring away from mains.

If wiring has to cross any high voltage cable this must be done at right angles.

Nodes must be mounted away from any high voltage equipment e.g. motors, door gear etc.

Mains power input and motor output cables should be shielded and earthed as per panel drawings.

Any screens in the trailing cable must be earthed at the panel end only.

Networks must be correctly terminated, with termination board on the landing network and with termination DIP's on the last car board in the system.